

SCULLY CONSULTING SERVICES

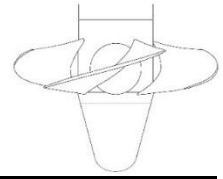

PO Box 338, Village of North Bennington, Vermont 05257 (802) 379-2469

The Paran Creek Watershed Project

September 29, 2016

Re: Request for Equipment Quotes

For your consideration,

Paran Creek Watershed Project is in the process of assessing the rehabilitation of two historic municipal hydropower facilities in North Bennington, Vermont, USA. At this stage we are evaluating options for equipment for the two sites. As such, we are requesting up to two budgetary quotations for a water-to-wire package, one for each of the two sites, based on the following information.

All proposed water conveyance features will be new. Manufacturers have considerable freedom in their recommendations for design at both sites. Please note that proposals for a single site and proposals for each of two sites will both be accepted. The Proposal need not match both sites.

The deadline for submissions is October 29, 2016.

Should you have any questions or need any further detail, please feel free to contact us at the number listed above or wfscully@gmail.com or liammcray@bennington.edu.

Thank you for your consideration. We look forward to your response.

William F. Scully & Liam O. McRae

29 September 2016

Quote 1, The Lake Paran Dam

Name: Lake Paran Dam
 Location: North Bennington, Vermont, USA
 Basin: Basin 1 – Batten Kill, Walloomsac, Hoosic River Basin

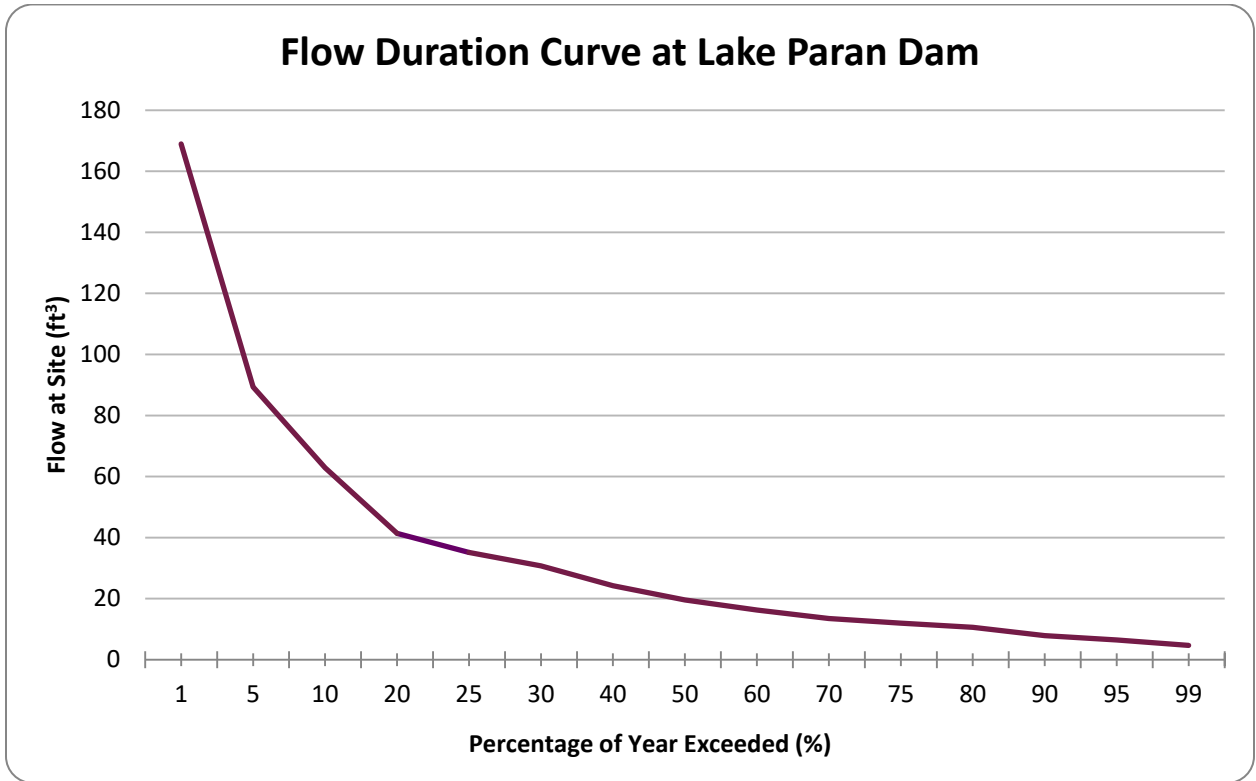

Flow Duration Statistics	
Percentage of Year Exceeded	Flow at Firehouse site (cubic feet per second)
1	168.93
5	89.32
10	62.85
20	41.35
15	52.10
25	35.15
30	30.74
40	24.26
50	19.57
60	16.26
70	13.51
75	11.99
80	10.61
90	7.87
95	6.48
99	4.69

Facility description:

The Lake Paran Dam was constructed circa 1840, allowing rail service into Bennington, VT. It was rebuilt circa 1980 due to leakage. It is a concrete overflow dam with an ogee gravity spillway.



The intake structure will be placed on river perpendicular to the upstream. A set of stop log gates will be located immediately after the trash racks and before the penstock gates. A new penstock will convey water to the new powerhouse. The diameter is yet to be defined. For this RFQ, please consider the powerhouse a blank slate apart from head, location and penstock water conveyance.

Equipment parameters

Head: 19.0625 feet gross head
Peak turbine flow: 48.57 ft³/sec
Type: Unspecified

Estimated Yield

Horsepower: 103.27
Net kW: 74.24

Conceptual Site Plan:

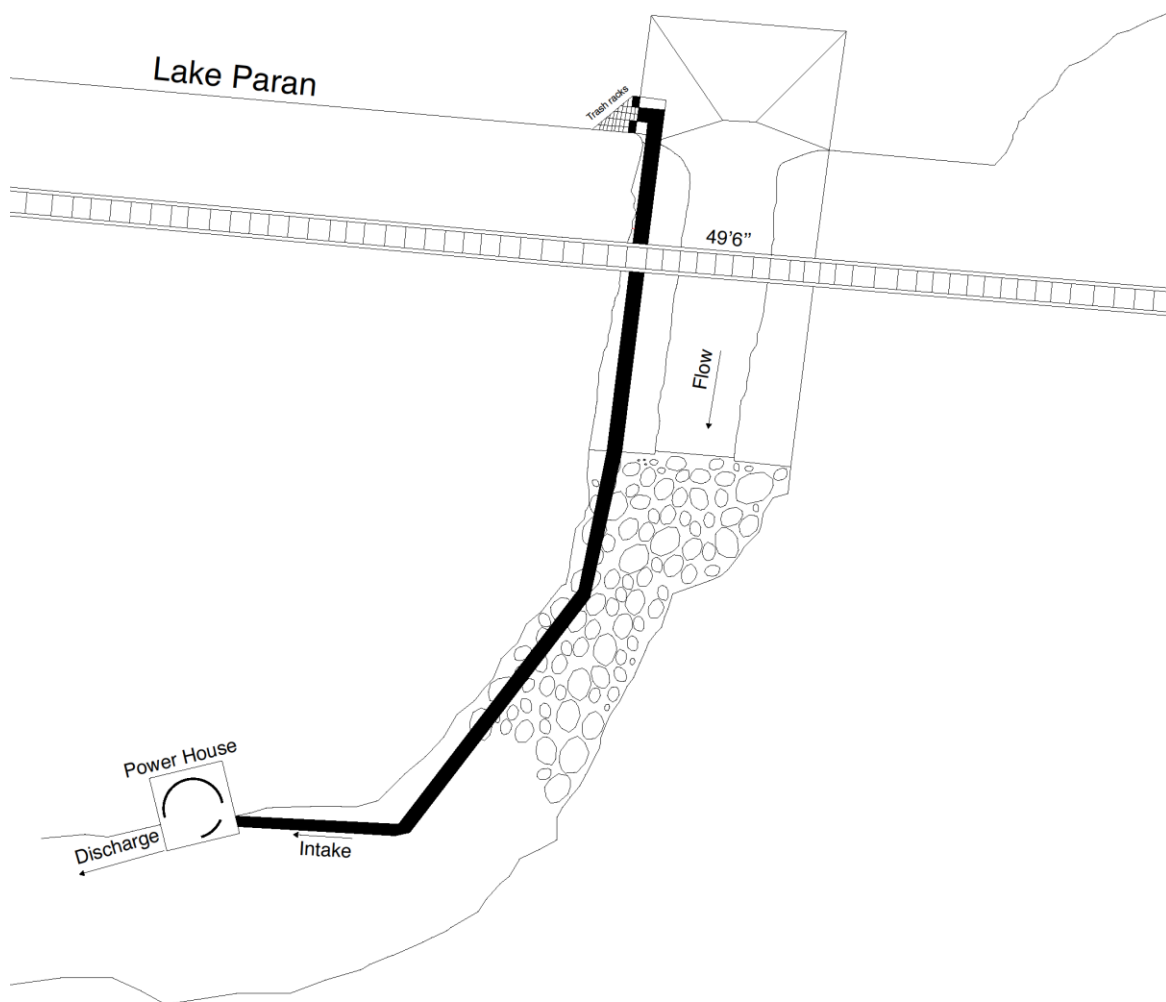

Quote 2, The Firehouse Dam

Name: Firehouse Dam
 Location: North Bennington, Vermont, USA
 Basin: Basin 1 – Batten Kill, Walloomsac, Hoosic River Basin

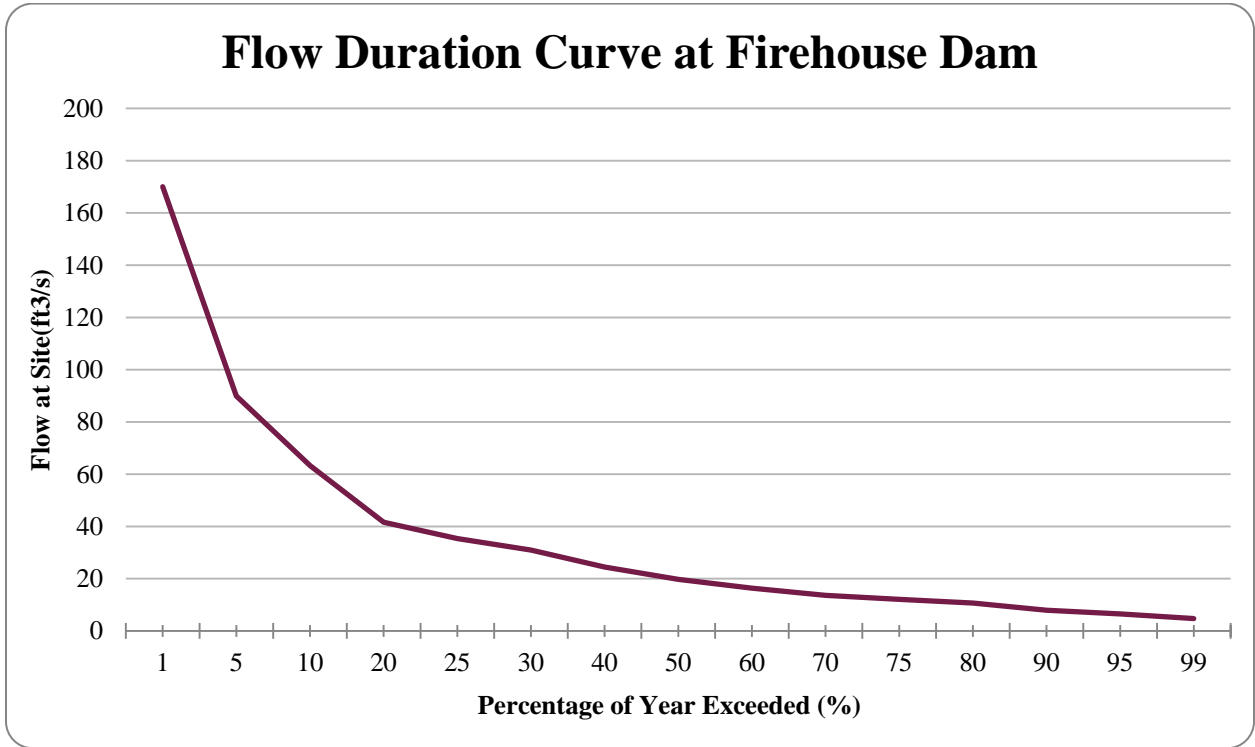

Flow Duration Statistics	
Percentage of Year Exceeded	Flow at Firehouse site (cubic feet per second)
1	170.04
5	89.90
10	63.26
20	41.62
15	52.44
25	35.38
30	30.94
40	24.42
50	19.70
60	16.37
70	13.60
75	12.07
80	10.68
90	7.91
95	6.52
99	4.72

Facility description:

The Firehouse Dam is a concrete overflow dam with a vertical gravity spillway.



The intake structure is as yet undefined other than assumed river left and incorporated into the powerhouse superstructure. The structure would include trashrack and headgates. For this RFQ, please consider the powerhouse a blank slate excepting head and orientation relative to the river.

Equipment parameters

Head: 12.042 feet gross head
Peak turbine flow: 48.38 ft³/sec
Type: Unspecified

Estimated Yield

Horsepower: 65.66
Net kW: 47.20

Conceptual Site Plan:

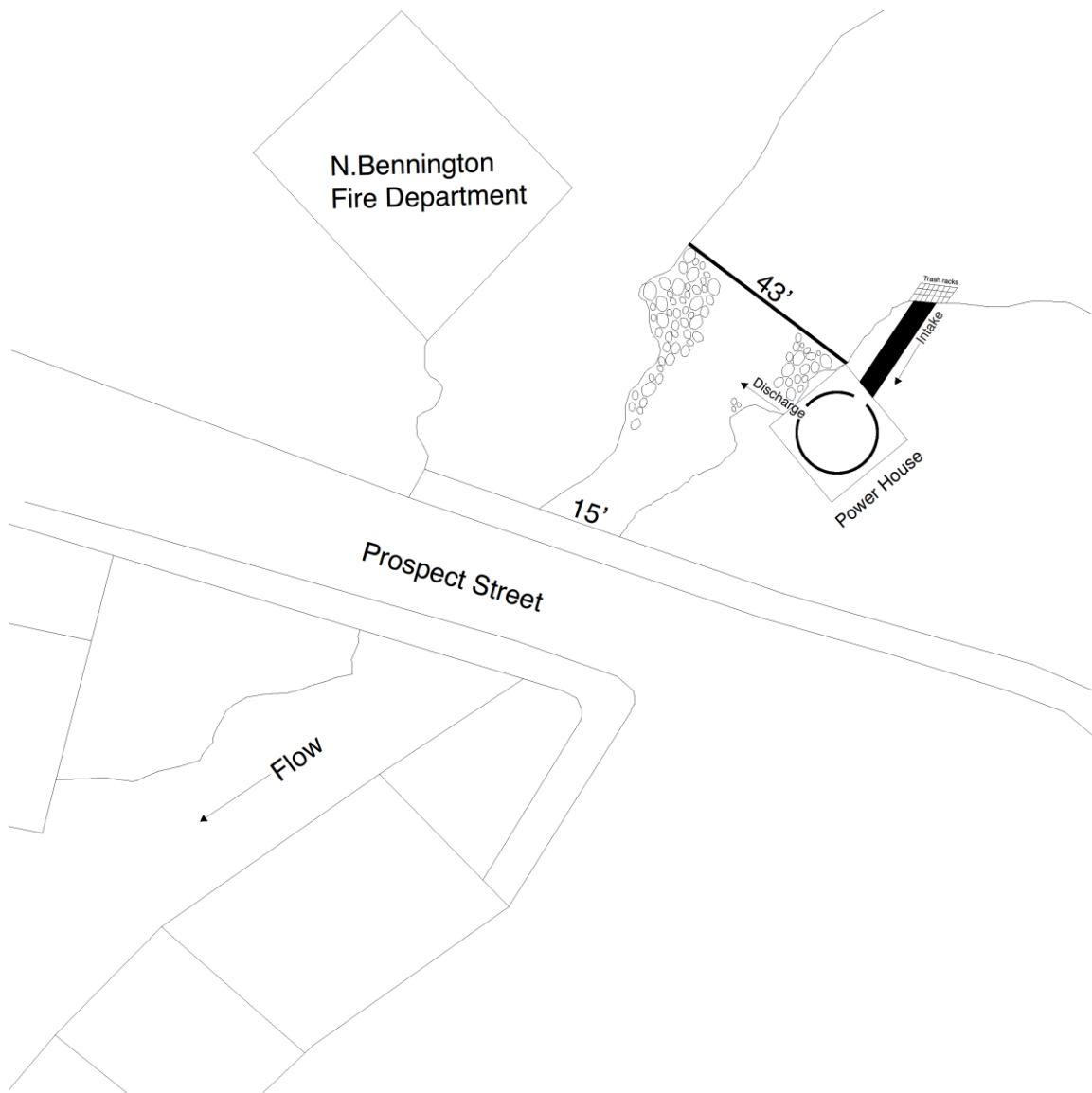

Requested Information for Both Dams:

Equipment:

- System efficiency curve to allow for the preliminary estimation of average annual generation calculation. Please provide individual system component efficiency ratings and curves for:
 - Turbine
 - Speed increaser
 - Generator.
- Preparer may include control, switchgear, wiring and transformer packages. Please detail these packages as separate line items (not lump sum) if applicable (this is not a quote requirement).
- Basic configuration drawings so that we can understand in simplest terms the civil works requirements. This should include an architectural drawing or rendering and may be generic and merely representative of the type of turbine proposed.
- List clearly all equipment included in quotation.

Services:

- List of all services included in quotation.
- Information on manufacturer installation services required beyond scope of quotation.

Assurances

- Provide any warranty and extended warranty information.
- Detail any production guarantees.
- All prices quoted must be good for 18 months.

All proposed water conveyance features will be new. Manufacturers have considerable freedom in their recommendations for design at both sites. Please note that proposals for a single site and proposals for each of two sites will both be accepted. The Proposal need not match both sites.

The deadline for submissions is October 29, 2016.

Should you have any questions or need any further detail, please feel free to contact us at the number listed above or wfscully@gmail.com or liammcrae@bennington.edu.

Client:

SCULLY CONSULTING SERVICES

North Bennington
Vermont, USA

Processor:

Contact: Mr. Markus PEHERSTORFER

Phone: +43 7282 5922 44

Fax: +43 7282 5922 21

Email: m.peherstorfer@wvs-wasserkraft.at

Subject:	Budget - Quotation	Date:	27.10.2016
-----------------	---------------------------	--------------	------------

Dear Mr. Scully

Thank you for your request from the 29.09.2016 regarding your small hydro power plant project.

We gladly offer you the following turbine(s):

Project: Lake Paran Dam

WWS-KSP525-5-600



BANK ACCOUNT

Raiffeisenbank Reg. Rohrbach
IBAN: AT83 3441 0000 0600 1994
BIC: RZ00AT2L410

VAT Reg. No./ COMMERCIAL REGISTER

ATU64372869
FN312926k
EORI: ATEOS1000018633

COMPLEMENTARY

Wasserkraft GmbH
head office: 4120 Neufelden
LG Linz, FN310635t



SUMMARY

I	TECHNICAL DATAS Turbine Design and Specifications	Page 3
II	PERFORMANCE & EFFICIENCY Efficiency & Output Graph Efficiency Table	Page 4
III	PRICE LIST Main Price List Optimal Equipment List Spare Part & Service Packages	Page 5
IV	SCOPE OF SUPPLY AND SERVICES	Page 7
A	Hydraulic Turbine 1 WWS-KSP525-5-600	Page 7
B	Turbine Accessories 1 Generator 2 & 3 Inlet Butterfly Valve & Dismantling Joint 5 Hydraulik Power Unit 6 & 7 Technical Documentation & Basic Consultation 8 Protection Covers & Railings	Page 10
C	Electrical Equipment 1 Turbine Control & Protection System 2 & 3 & 4 Low Voltage Switch Syst. & Main Power Transformer & Med. Voltage Switch Syst. 5 & 6 Battery Syst. & DC distribution 24V & SEAMTEC SCADA Basic System 7 & 8 Fault Message Service & Remote Operation 9 & 10 Power Cable Set and Cable Trays & Engineering & Documentation	Page 16
D	Erection & Training 1 & 2 Erection on site & Commissioning and Training 3 Travelling Costs	Page 26
E	Packaging & Transport 1 & 2 Packaging & Transport	Page 27
F	Optional Equipment	Page 28
G	Spare parts	Page 38
H	M & S Package	Page 40
V	TURBINE MEASUREMENTS (preliminary)	Page 42
VI	TERMES OF PAYMENT	Page 43
VII	TIME OF DELIVERY	Page 44
VIII	CONTRACT CONDITIONS	Page 45

I) TECHNICAL DATAS	Project Name:	Lake Paran Dam
---------------------------	---------------	-----------------------

1	Unit(s)				
Turbine Type:		WWS-KSP525-5-600			
Kaplan spiral turbine with directly coupled generator					
Gross Head: 19,06 feet		5,8	m		
Net Head:		5,4	m	Total Discharge Volume:	
Discharge Volume:		1,38	m ³ /s	48,57	ft ³ /s
Turbine Speed:		600	rpm	1,38	m ³ /s
Runner Blades		5			
Runner Diameter:		525	mm		
Turbine Power Output:		64	kW	Total Turbine Power Output:	
Generator shaft		horizontal		64	kW
Generator Speed:		600	rpm		
Generator Voltage:		400	V		
Generator Power Output:		59	kW	Total Electrical Power Output:	
Nominal Generator Power:		70	kVA	59	kW
Grid Voltage:		---	kV		
Frequency:		60	Hz		
Inlet Valve Diameter		700	mm		
Penstock Diameter:		---	mm		
Suction head		---	m		
Altitude a.s.l.		---	m a.s.l.		

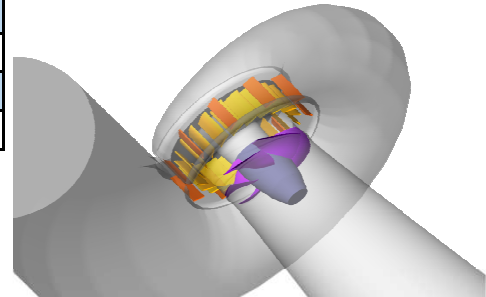

II) PERFORMANCE & EFFICIENCY	per Unit at rated net head of:	5,4	m	
---	--------------------------------	------------	----------	--

The Turbines are manufactured at WWS Wasserkraft GmbH & Co KG. Every hydraulic profile was developed with a numeric simulation performed by the renowned technical university of Graz, Austria and guarantess highest efficiency. The below mentioned values are stated with a margin for safety and higher efficiency can be expected in operation.

QT	Turbine Discharge	Net Head	Efficiency Turbine	Turbine Output	Efficiency Generator	Generator Output	
%	m ³ /s	m	%	kW	%	kW	
20	0,28	5,40	86,0%	12,6	88,0%	11,1	
30	0,41	5,40	88,0%	19,3	90,0%	17,4	
40	0,55	5,40	89,5%	26,2	91,0%	23,8	
50	0,69	5,40	90,3%	33,0	91,6%	30,2	
60	0,83	5,40	90,6%	39,7	92,1%	36,6	
70	0,97	5,40	90,5%	46,3	92,3%	42,7	
80	1,10	5,40	89,9%	52,6	92,3%	48,5	
90	1,24	5,40	88,7%	58,4	92,3%	53,9	
100	1,38	5,40	87,5%	64,0	92,3%	59,0	

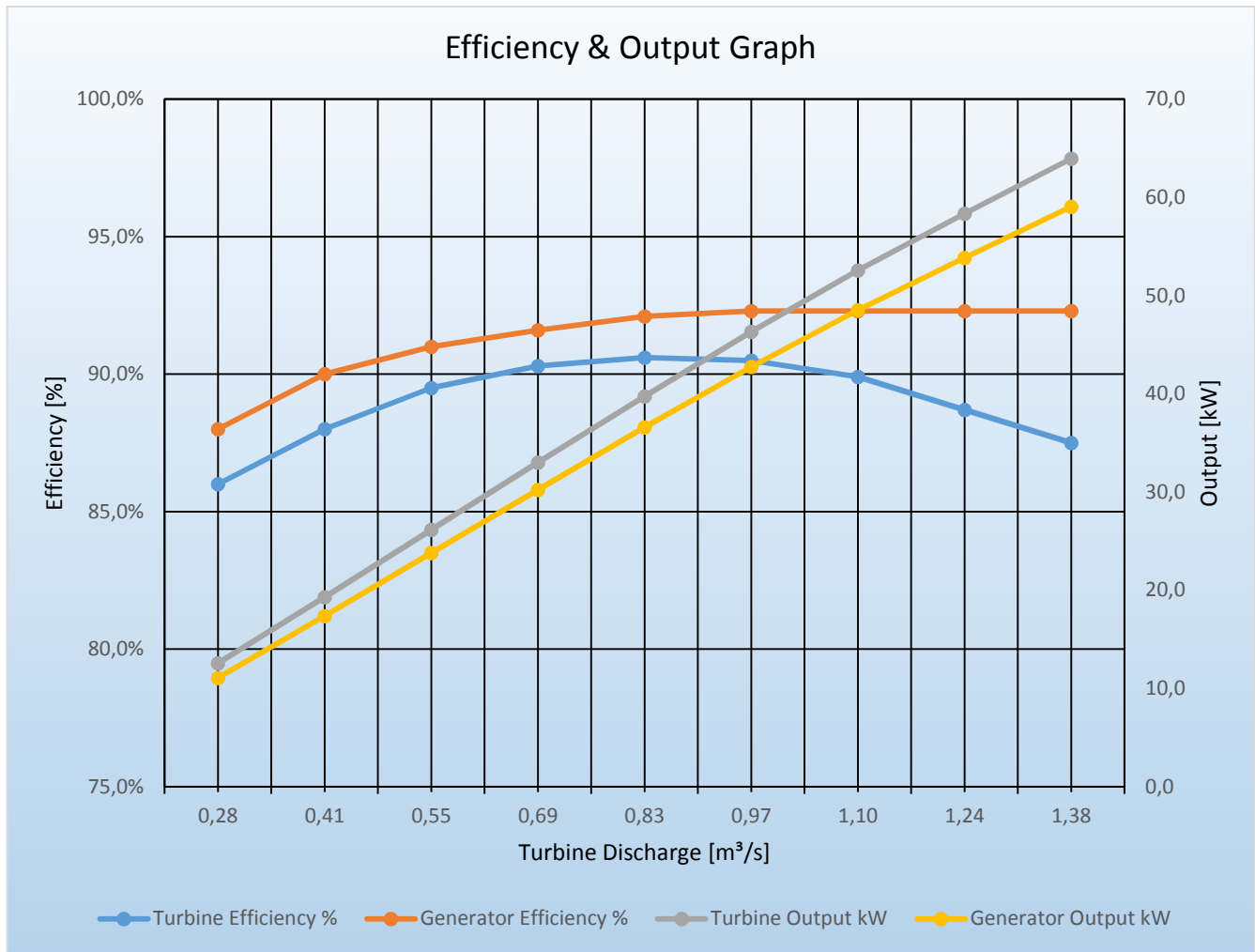

III) PRICE LIST	Project Name:	Lake Paran Dam
------------------------	---------------	-----------------------

Pos.	Part	Qty:	Unit Price:	Price
1	WWS-KSP525-5-600	1	€ 98.000	€ 98.000
&	Standard Wicket Gate Ring	1		included
&	Machined Guide Vanes	1		included
A	TOTAL PRICE Hydraulic Turbine			€ 98.000

1	Generator	400V	600rpm	70kVA	1	€ 38.600	€ 38.600
		1000msl	Roller Bearing			Options: € 0	
2	Inlet Butterfly Valve	DN 700	PN 6		1	€ 14.400	€ 14.400
3	Dismantling Joint	DN 700	PN 6		1	€ 2.400	€ 2.400
4	Draft Tube Cone & Elbow	(preliminary)			1	€ 6.300	€ 6.300
5	Hydraulik Power Unit	Size:	M = 100L		1	€ 12.100	€ 12.100
6	Technical Documentation				1	€ 1.200	€ 1.200
7	Basic Consultation				1	€ 5.800	free of charge
8	Protection Covers & Railings		CE		0	€ 3.000	Option
B	TOTAL PRICE Turbine Accessories						€ 75.000

1	Turbine Control & Protection System				1	€ 23.400	€ 23.400
2	Low Voltage Switch Syst.	400V	60 Hz		1	€ 19.600	€ 19.600
3	Main Power Transformer	---/0,4kVA	100 kVA		0	€ 0	Option
3a	Aux. Unit Transformer	0,4/0,4kVA	100 kVA		0	€ 0	Option
4	Med. Voltage Switch Syst.	---	--		0	€ 0	Option
5	Battery Syst. & DC distribution 24V		45 Ah		1	€ 2.200	€ 2.200
6	SEAMTEC SCADA Basic System				1	€ 7.300	€ 7.300
7	Fault Message Service				0	€ 2.500	Option
8	Remote Operation				0	€ 2.200	Option
9	Power Cable Set and Cable Trays		L= 10 m		1	€ 4.300	€ 4.300
10	Engineering & Documentation				1	€ 3.200	€ 3.200
C	TOTAL PRICE Electrical Equipment						€ 60.000

1	Erection on site				1	€ 18.500	€ 18.500
2	Commissioning and Training				1	€ 1.700	€ 1.700
3	Travelling Costs				1	€ 7.500	€ 7.500
D	TOTAL PRICE Erection & Training						€ 27.700

1	Packaging				1	€ 3.400	€ 3.400
2	Transport	WWS - USA	CFR		1	€ 4.600	€ 4.600
E	TOTAL PRICE Packaging & Transport						€ 8.000

F	TOTAL PRICE Optional Equipment						€ 0
G	TOTAL PRICE Spare parts						€ 0
H	TOTAL PRICE M & S Package						€ 0

	TOTAL PRICE						€ 268.700
--	--------------------	--	--	--	--	--	------------------



Please see next page for prices of optimal equipment and other services!

Optional Equipment List

Upon request to optimized your power plant!

Pos.	Part				Qty:	Unit Price:	Price
1	Inlet Pipe	L=5000	---	PN 6	0	on request	Option
2	Bypass Valves		DN 600	PN 6	0	on request	Option
3	2nd Pump unit for HPU	DC		230V	0	€ 1.700	Option
4	Humidity Absorbing Filter for HPU				0	€ 400	Option
5	Proportional Valves for HPU				0	€ 2.200	Option
6	Biodegr. Oil for HPU	Panolin		M = 100L	0	€ 750	Option
7	Grease Pump f. Sealings	DC		24V	0	€ 1.900	Option
8	Wicket Gate Monitoring	Qty.		18	0	€ 5.400	Option
9	Bridge Crane incl. Rails	100 kN		L=10m	0	on request	Option
10	SEAMTEC SCADA Enterprise System				0	€ 16.800	Option
11	Condition Monitoring	4 Sensor(s)			0	€ 6.270	Option
12	Redundant CPU Solution				0	€ 8.000	Option
13	Monitoring Camera - Outdoor				0	€ 2.500	Option
14	Camera Surveillance System			3 Cams	0	€ 12.310	Option
15	Weather Station				0	€ 5.500	Option
16	Additional Water Level Sensor			20m Cable	0	€ 1.200	Option
17	Smoke Detector - Power House				0	€ 500	Option
18	Electrical Installation - Power House				0	on request	Option
19	Ventilation System - Power House			3800m ³ /h	0	€ 640	Option
20	Temperatur Sensor - Power house			PT100	0	€ 380	Option
21	Generator Neutral Cubicle				0	€ 7.900	Option
22	Transformer Neutral Cubicle				0	€ 8.200	Option
23	Diesel Generator	400V	60 Hz	60 kVA	0	€ 17.000	Option
24	QA/QC Protocol for all equipment				0	€ 4.500	Option
25	Fly-wheel	I (GD2) = unknown			0	on request	Option
26	Separate shaft and bearings	Roller Bearing			0	on request	Option
27	Elastic Coupling				0	on request	Option
F	TOTAL PRICE Optional Equipment						€ 0

Spare Parts

Containing wear parts, sealings, valves, sensors, limit switches ect.

Pos.	Part				Qty:	Unit Price:	Price
1	Spare Parts Turbine / Main Valve				0	€ 0	Option
2	Spare Parts Generator				0	€ 0	Option
3	Spare Parts (Governor, Hydraulic power unit)				0	€ 0	Option
4	Spare Parts Electrical Equipment				0	€ 0	Option
G	TOTAL PRICE Spare parts						€ 0

Maintenance & Service Packages (per anno)

For detailed description check point II) H in the technical description below

Pos.	Part				Qty:	Unit Price:	Price
1	Maintenance Contract				0	€ 0	Option
2	Service Package Standard				0	€ 0	Option
3	Service Package Premium				0	€ 0	Option
4	Service Package All Inclusive				0	€ 0	Option
H	TOTAL PRICE M & S Package						€ 0

LIST OF EXPECTED COSTS FOR SUPERVISION / INSTALLATION, COMMISSIONING AND TRAINING

Costs already included in above price list!

Installation Team usually consists of 2 mechanical engineers and 2 electrical engineers

Units	Equipment	Days	Day rate EURO	TOTAL EURO
1	Turbine	6	€ 800	€ 4.800
1	Generator	2	€ 800	€ 1.600
1	Inlet Valve & Dismantling Joint	1	€ 800	€ 800
1	Hydraulic Power Unit & Piping	2	€ 800	€ 1.600
1	Cable Set & Cable Trays	2	€ 800	€ 1.600
1	Electrical Equipment & Control Panel	9	€ 900	€ 8.100
0	Optional Equipment	0	€ 850	€ 0
1	Commissioning & Training	2	€ 850	€ 1.700
1	Travelling Time	5	€ 700	€ 3.500
1	Travelling Costs / Tickets ect.	4	€ 1.000	€ 4.000
1	TOTAL PRICE Installation & Training			€ 27.700

IV) SCOPE OF SUPPLY AND SERVICES

A Hydraulic Turbine

Preface

Including Kaplan runner directly mounted onto the generator shaft, turbine housing and hydraulically regulated guide vanes. Hydraulically double regulated turbine set with adjustable runner blades as well as regulated guide vanes at the wicket gate to maximize efficiency over the entire load range. All parts are calculated, designed and manufactured by WWS Wasserkraft and made accurately to European EN Standards. All materials used by WWS Wasserkraft are new, of high quality and internationally standardized. WWS turbines are designed to run on low maintenance and developed for long life time.

Turbine Housing:

The helical housing is a welded structure made of steel S355J2+N (1.0570) according to DIN EN10025-2. With anchors for embedding in concrete and stiffening ribs for support. The complete housing is hot-dip galvanized if possible otherwise coated with Zinga® before it gets primed and painted with RAL industrial paint (colour as desired). To assure maximum safety and quality of our welded structures the turbine housing will undergo a pressure test with pressure 1,5 times higher than the working pressure to prevent damage of the housing or the weldings due to water hammer effect or pressure peaks during production.

The customized turbine housing design consists of two maintenance/inspection holes as well as pressure measurement points. At the top point of the housing is a manual ball valve to vent trapped air from the housing. At the lowest point of the housing is another manual ball valve to drain the turbine.



Turbine Shaft

Not equipped - Runner is directly mounted onto the generator shaft. As a result the design will be more compact, the turbine will have less rotating parts that need to be maintained and simply be more economic. The generator shaft and generator bearing will be especially designed and calculated for the specified maximum turbine forces by the generator supplier and adapted for the customized WWS Wasserkraft hydraulic turbine.

Turbine Shaft Bearings

Not equipped - Main bearing implemented into generator. As a result the design will be more compact, the turbine will have less rotating parts that need to be maintained and simply be more economic. The generator shaft and generator bearing will be especially designed and calculated for the specified maximum turbine forces by the generator supplier and adapted for the customized WWS Wasserkraft hydraulic turbine.

Turbine Shaft Sealing:

Consisting of specialized and corrosion-free labyrinth sealing as well as two additional rotary shaft seals. The sealings are prepared for grease lubrication with bio-degradable grease and run on hardened and stainless steel protection bushings.

Kaplan Runner Blades:

Kaplan runner blades made of Aluminum-Nickel-Bronze casting (G-CuAl10Ni). Designed according to a proven geometry calculated and simulated by the Technical University of Graz. Fitted onto the runner hub with a perfect fit, sealing rings as well as counter-mounted track disk which allows the blades to still be able to rotate.

On request the Kaplan runner blades can be also made out of stainless steel X3CrNiMo13-4 (1.4313) to achieve highest wear resistance and life time.



Runner Hub:

Made of spheroidal cast iron EN-GJS-500-7. Sealed with maintenance free sealings. Housing is oil filled, also including runner blade adjustment mechanism. Fixed onto the turbine shaft by means of an oil press-fit.



Protection Bushing:

Bushings are made of hard-chrome plated stainless steel (1.4301) and fixed onto the extended generator shaft with three grub screws. Two O-rings seal the gap between shaft and bushing. The bushings protect the generator shaft from wear so the shaft sealing can run on the protection bushings without damaging the generator shaft itself. In case of high abrasion the bushings can be exchanged easily and cost-efficiently.

Wicket Gate Mechanism:

The water flow through the turbine is controlled via an adjustable wicket gate mechanism which acts as flow control unit and as primary closing device at the same time. The opening and closing of the wicket gate happens via a double acting hydraulic cylinder.

Wicket Gate Ring:

Two wicket gate rings (the first ring is located at the generator side and the second ring which is facing to the draft tube) made of steel S355J2+N (1.0570).

The wicket gate rings will be machined for highest precision and minimal gap variation. For corrosion protection the wicket gate ring will be painted with durable tar paint. Both wicket gate rings are clamped onto the turbine housing and fixed with screws.



Guide Vanes:

The guide vanes are designed as hydro-dynamic flow pattern and are made of wear resistant stainless steel X3CrNiMo13-4 (1.4313) and are machined on a CNC mill-turn machine to achieve high precision parts with low tolerances. Each guide vane has a trunnion on the top and bottom side which are received in maintenance free and self-lubricated guide vane bearing bushings for smooth movement.

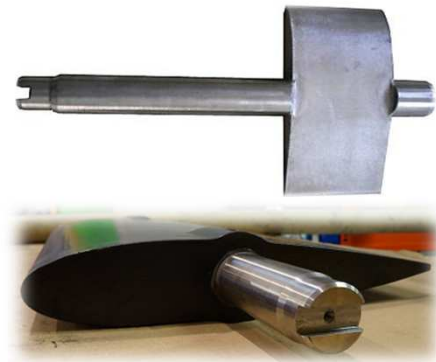

Adjusting Rod:

Made of C45E (1.1191)

Connected from the runner blade adjustment mechanism, guided through the hollow turbine shaft to the outside of turbine / generator and connected to the double acting hydraulic cylinder to adjust the blade position angle.

Guide Vane Bearing Bushings:

Exchangeable oil-free bushes. Bottom-side bearing bushings are made of sintered bronze and the top-side bearing flange is made of CuZn38Pb2 (2.1090.01). The top side bearing flange uses sealing rings to prevent leakage and is fixed on the generator site wicket gate ring with screws.

Wicket Gate Chain Link:

To operate and move the guide vanes simultaneously via a chain link and link pin system. Every link connected to the guide vane is fixed with a torque limited clamping unit which will allow to slip over in case a guide vane cannot move due to some debris stuck between guide vanes (machine breakage prevention). As a result the wicket gate operating ring can still be operated without causing damage. The guide vane has an optical indicator and can easily be readjusted in case of shift.



Wicket Gate Regulation:

The wicket gate will be automatically and regulated with a double-acting hydraulic cylinder mounted on the turbine housing. The piston rod is connected to a lever attached to the wicket gate operating ring. The position of the guide vanes can be supervised due to a linear potentiometer sending a feedback to the turbine control system and an additional optical indicator directly on the hydraulic cylinder.



Corrosion Protection:

All connection elements which are in contact with water are made of stainless material. As far as parts are not made of corrosion-resistant material the parts will undergo the following treatment to prevent corrosion:

Welded steel structures (turbine housing, draft tube, etc):

fully hot dip galvanized otherwise protected with Avenarius - Agrozinc SW

Surfaces in contact with water:

Sandblasted SA 2 ½,
2 priming coats with Agrozinc SW, 50µm each
2 top coats with Avertol Epotar, 200µm each

Hot-dip galvanised surfaces in contact with air:

1 top coat with Agropur Color ST, 100µm

Other surfaces in contact with air:

Sandblasted SA 2 ½,
2 priming coats with Agrozinc SW, 50µm each
1 top coat with Agropur Color ST, 100µm

Concreted areas:

No treatment

Description:

Agrozinc SW is a epoxy resin paint with zinc dust made by Avenarius Agro GmbH Germany
Avertol Epotar is a tar-oil epoxy compound made by Avenarius Agro GmbH Germany
Agropur Color ST is a 2-component-Polyurethane top coat made by Avenarius Agro GmbH Germany and is available in all RAL colour standards. WWS Wasserkraft uses RAL3000 (red) or RAL5010 (blue). Other colours can be used on request.

B Turbine Accessories

1 Generator

Three phase generator with brushless synchronous alternator with built-in self exciter machine and control system. The grid code, electrical connection conditions and standards of the grid operator need to be published.

Brand	West-European (Hitzinger, AEM, ...)	
Nominal output	[kVA]	70
Ambient temperature	[° C]	40
Altitude max.	[m]	1000
Power factor	-	0,9
Nominal voltage	[V]	400
Connection	-	star
Voltage regulation accuracy	[%]	+/- 1,5
Voltage adjusting range	[%]	+/- 10
Speed	[min ⁻¹]	600
Overspeed	[min ⁻¹]	1080
Frequency	[Hz]	60
Isolation class	-	F
Temperature rise	-	B
Protection class	-	IP 21
Cooling system	-	IC 01
Sound level	[dB]	< 95 +/-3
Design	-	B3
Bearing	-	Roller Bearing
Minimal Bearing Life Time	[h]	>100.000 h
Radio interference suppression	-	N
Specification standard	-	VDE 0530, IEC 34
Damper winding for parallel operation	-	100 % unbalanced
Short Circuit Ratio	-	<0,75
Painting	-	RAL 2008
Shaft rotation	-	optional
Voltage rotation	-	right
Cable outlet	-	down
Max. stops per day	-	3 stops/day



Efficiency:

Work Load	Efficiency in % at cos phi	
	0,9	1,0
100% load	91,7%	92,3%
75% load	91,7%	92,3%
50% load	91,1%	91,6%
25% load	88,1%	89,0%

Generator Accessories:

- Voltage regulator BASLER DECS100 or similar, installed
- Set value potentiometer for voltage adjustment, loose
- Static unit for parallel operation
- Control voltage at frequency lowering
- Cos Phi regulator and transformer installed
- Temperature sensor PT 100 in stator winding, 1 pcs.per phase
- Winding head support wedges for excessive speed centrifugal
- Blanking plate with cable outlet
- Bearing temperature supervision PT100, 1 pcs. per bearing
- Reinforced bearings AS for receiving the turbine axial and centrifugal forces
- Foundation frame

Documentation:

- Operating and Maintenance Manual
- Power Connection Circuit Diagram
- Wiring Diagram
- Dimensional Drawing

Tests and Certificates:

- No-load characteristic
- Short circuit characteristic
- Heating test- resistance method
- H.V. test 0 Hz / 1 min.
- Centrifugal test- 2 min.
- Insulation measuring
- Adjusting of voltage- and cos phi regulator

The generator is the part with the highest noise level. The reason for this sound level is the cooling fan. This noise level can be reduced with a water cooled generator.

Optional Design & Technical Features for Turbine Generator

Pos.	Part			Qty:	Unit Price:	Price
1	Idle State Heating	230V	1000W	0	€ 1.200	Option
2	Water Cooling System			0	on request	Option
3	Sleeve Bearing + Lubrication System			0	on request	Option
4	External Lubrication System			0	on request	Option
5	Voltage & Current Transformer			0	on request	Option
6	BASLER DECS 250 instead BASLER DECS 100			0	on request	Option
7	Vibration Control			0	on request	Option
8	Short Circuit Ratio > 0,75	Value:	0,8	0	on request	Option
to B 1	TOTAL PRICE Generator Options					€ 0

2 Inlet Butterfly Valve

Diameter [mm]: **700**
Pressure Stage: **PN 6**

Brand: Falkner Valves, Austria

Counterweight with hydraulic cylinder: connected to turbine hydraulic power unit and emergency shut off due to counterweight for maximum safety and reliability. Closing time adjustable by manual throttle check valve. Recommended by WWS Wasserkraft!

Features:

Large range of pressure rates and sizes
Practically verified design
Low-wearing main seal (by double offset disc)
Absolutely tight seal in the main flow direction
Maintenance free, no lub points

Part Materials

Design: Double flanged, double eccentric, streamlined profile according to DIN (German Industrial Standard)
Flanges: EN 1092-2 PN 10, 16, 25
Body and Disc: EN 1563 EN-GJS-400-15 ductile iron (GGG 40)
Sealing ring: EPDM rubber
Shaft: 1.4021 stainless steel (X20Cr13)
Body seat: Stainless steel weld overlay and microfinished
Retaining ring: St 37 carbon steel
Bearing bush: Bronze
Limit switches: 3 pieces (open/close/10%... or other)
Coating: Two pack Epoxy, RAL 5017, min. 300 microns
Hydrostatic tests: 1.5 x PN body strength test
1.1 x PN leakage test



3 Dismantling Joint

Diameter [mm]: **700**
Pressure Stage: **PN 6**

Brand: Falkner Valves Austria

Design:
Flange connections according to EN1092-2 and made of ductile cast iron.
Full studs and bolts for fixation
+/- 25mm axial movement
Sealings made of EPDM rubber
Middle flange made of carbon steel
Coating: two pack Epoxy, RAL; 300µm
Pressure tested at 1,5 times of nominal pressure

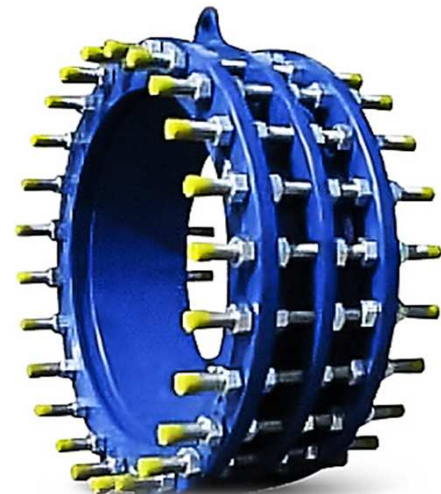

4 Draft Tube Cone & Elbow

Designed as a welded steel structure made of S355J2+N (1.0570) containing draft tube, draft tube elbow and draft tube end depending on layout. Draft tube customized according to technical specifications, site conditions and hydro-dynamic requirements. Draft tube price will depend on the final layout of turbine and specific design of the draft tube (negative or positive suction head, bend or straight, elbow type, square or round section, ect....). Draft tube is connected to turbine housing via a flange with screws. Draft tube also containing a pressure manometer to check pressure and suction head. Also includes inspection hole for maintenance. With anchors for embedding in concrete foundation and rigidstiffening ribs if necessary to assure maximum stability and compressive strength. Draft tube fully hot-dip galvanized if possible otherwise corrosion protection with Zinga[®]. Draft tube areas embeded in concrete will have no surface treatment for better bonding.

Inlet diameter (turbine side)	530 mm
Discharge diameter (tail water)	1.330 mm
Length of entire draft tube	4.810 mm
Approximate weight:	1085 kg
Parts (depending on layout):	2-3

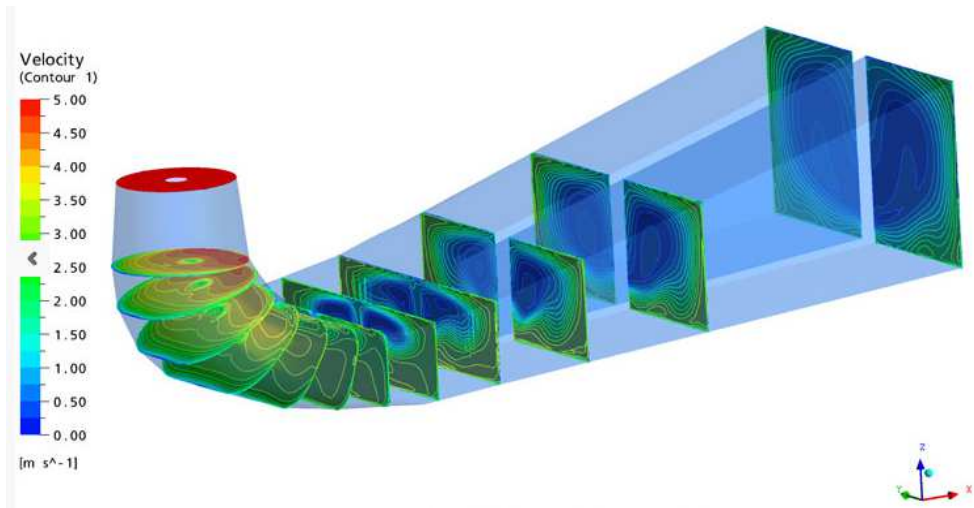
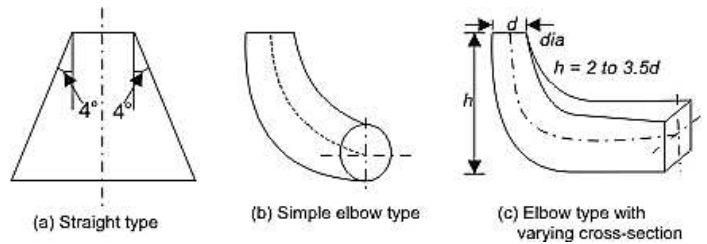

5 Hydraulik Power Unit

Estimated size: M = 100l Liters of Oil

Hydraulic Power Unit in compact design, completely pre-mounted and painted, to be placed nearby the turbine.

Functionality: The operating pressure will be worked off from the pressure accumulator until the minimum pressure is reached. Only if the working pressure falls below the minimum pressure the accumulator will be refilled by the pump. The pump will shut off as long as the pressure in the accumulator is high enough to avoid overheating and overpressure and increase pump lifetime. In powerless state the pressure can be build up with a manual pump to actuate the hydraulic cylinders. Biodegradable oil can be used on request.

The pump consist of the following main parts:

- Pressure Switch for the pump control
- Pressure Accumulator with safety pressure switch
- Oil tank with filler neck
- Oil drain plug
- Vent filter
- Oil level indicator
- Temperature switch
- Visual and electrical oil level control (alarm)
- Return flow filter
- Pressure filter
- Manual pump (to start up machine in powerless state)
- Gear pump
- Three phase motor 400V
- Pump check valve and overpressure valve



Hydraulic Power Unit tailor-made by WWS Wasserkraft according to turbine specifications!

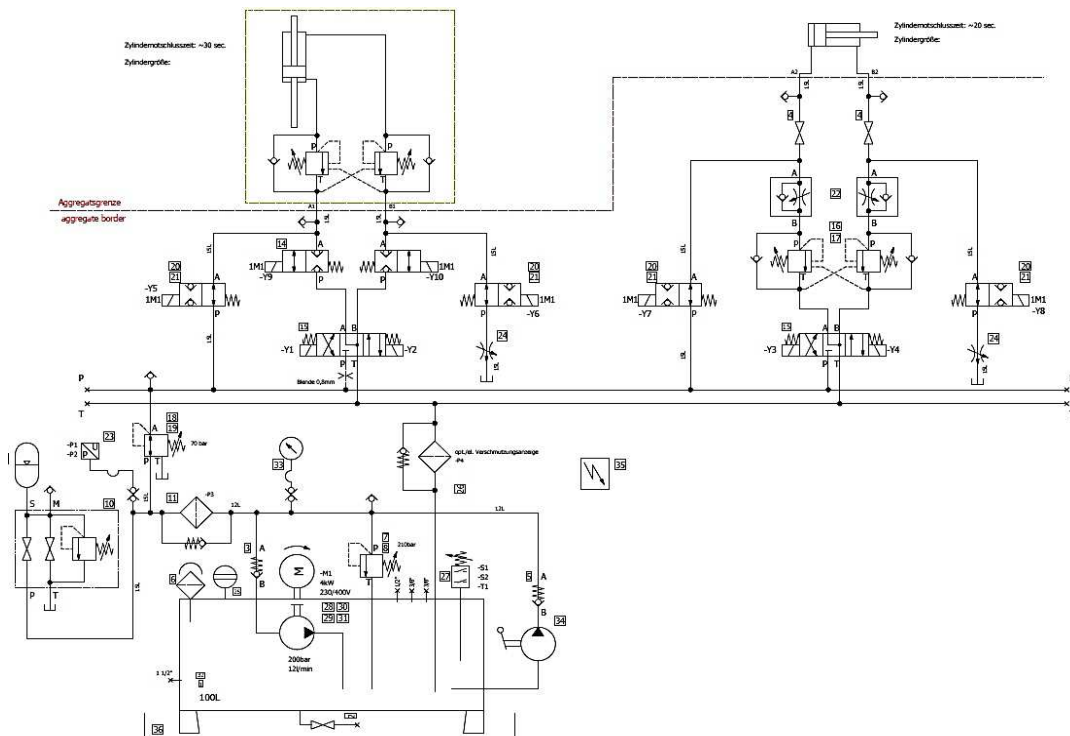

6 Technical Documentation

Detailed technical documentation of the whole equipment in English language and colour, submitted to the customer as printed version after commissioning. Containing the latest settings and values of the equipment. Including the following documents:

Operating Manual
Maintenance Manual
Installation Drawings
Assembly Drawings
Testing Protocols
Hydraulic Scheme
Wiring Diagrams
Spare Parts List
Manuals of purchased parts



7 Basic Consultation

WWS Wasserkraft will give you support in the development of your hydro power plant project **free of charge** based on our long-standing experience :

- Support in design of intake and power house
- Consultation on site
- Calculation of annual production according to yearly flow diagram
- Customized design of equipment



8 Protection Covers & Railings

Covers and Railings made for ducts, shafts and rotating parts or other areas and parts that need to be protected accordingly. For example belt transmissions, turbine shafts, deep ducts, ect. Executed according to the CE machinery directive 2006/42/EG .



C Electrical Equipment

1 Turbine Control & Protection System

including control cables and wiring

Operation Principles

Default settings:

Turbine control and protection system optimized for a WWS Kaplan spiral turbine with wicket gate regulation in modular design. The control system is developed for reliable and unattended operation and assures fully automated running mode and well as a manual control mode for feeding the generated electricity into the main grid. The machine can be managed and controlled via a HMI-touch panel in the power house. All fault messages are collected in a sum report and indicated on the screen and in case the machine will be brought into a safe mode. The measured values necessary for operation and icons of all machine elements are shown graphically on the HMI panel. The machine sets are started, synchronised and turned off automatically as defined by a respective control command (process control). Furthermore it is possible to have remote supervision via SCADA system.

Adjusting and Re-starting:

It is guaranteed that the plant is automatically stopped without any external power source in the event of the failure of a preceding net or an emergency stop or adjustment command as a consequence of inadmissible operational states from the turbine or the electrical equipment.

If the plant has been stopped through an external failure it is automatically re-started after the re-start of the preceding net.

If the plant was stopped due to an internal failure it remains blocked. After the failure has been eliminated operability is secured without any special measures and the plant can be re-started either automatically or manually.

Elimination of risks:

The closure of the shut-off organ happens independently from external energy and is secured through stop valves in closed current mode and/or closing weights.

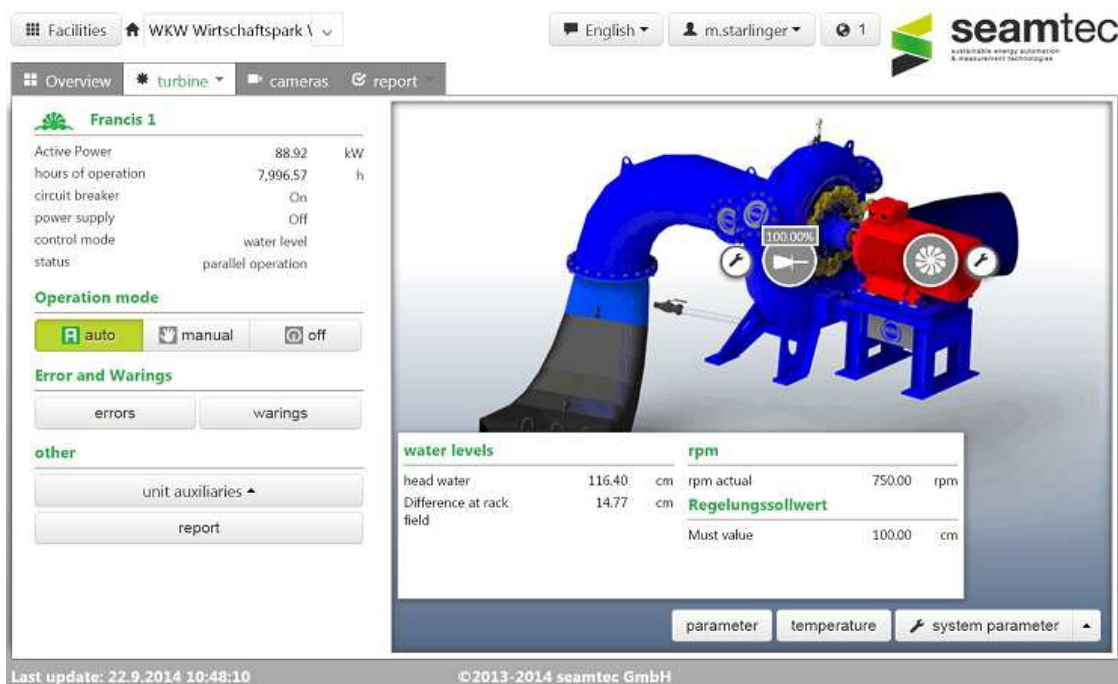

Operating Modes:

Automatic Mode:

The turbine starts automatically and synchronizes with the main power grid. In case of failure or power break down the turbine will shut down automatically until failure is fixed or power in grid returns. Then the machine will be restarted and synchronized with the main power grid.

In automatic mode following control modes are available:

Water Level Control:

Via a water level sensor the turbine will process the adjusted amount of water.

Flow Control:

The turbine will work on a preset discharge volume.

Output Control:

The turbine will work on a preset nominal output.

Manual Mode:

In manual mode it is possible to control wicket gate and other control elements manually via the touch panel.

Technical Data:

Supply Voltage: 230/400V
System Voltage: 24V DC
Surge Class: CAT III
Current: 63A
Isolation Class: IP55
Color: RAL7035

15" Multitouch Panel PC
B&R X20 CPU
B&R X20 modular I/O system
B&R X20 digital outputs 24VDC, 0,5A
B&R X20 digital inputs 24VDC
B&R X20 2 analog inputs (4-20mA)
B&R X20 8 PT100 temperatur inputs



- 1 Control Unit Cabinet (800x2000x600)
Make: SEAMTEC
TYPE: RITTAL TS8
Protection Class: IP54

Approbations TS8 Control Cabinets:

UL	Russian Maritime Register of Shipping
CA	Lloyds Register of Shipping
TÜV & TÜV Mark	Bureau Veritas
VDE	Germanischer Lloyd

The control unit fulfills the following tasks:

- Automatic starts and stops the turbine
 1. Single step control
 2. Reporting of start-up readiness
 3. Step display
- Fault indication systems: temperature control, limit switch control, pressure switch control
- Auxiliary drive operation control
- Water way control
- Station service control: Control of transformers, AC/DC supply system, medium voltage system
- Touch Panel (HMI)
- Automatic stop and start-up procedure executed as a process chain:
- Turbine governor system

Synchronisation & Basic Protection System:

Before switching the generator into the net a automatic voltage equalisation is carrier out. The generator may only be switched on within and adjustable admissable voltage difference. Additionally an automatic frequency equalization guarantees a quick approach of the turbine to the nominal rotation speed (rpm).

Make: B&R

Type: CM0985

The CM0985 has a compact size and combines a power measurement module that has special features with a synchronization unit that is able to meet all demands.

- Energy measurement for 120 - 480 VAC
- Simultaneous measurement of two AC networks plus two additional voltages
- For multifunctional measurement tasks
- Intelligent mains network synchronization unit

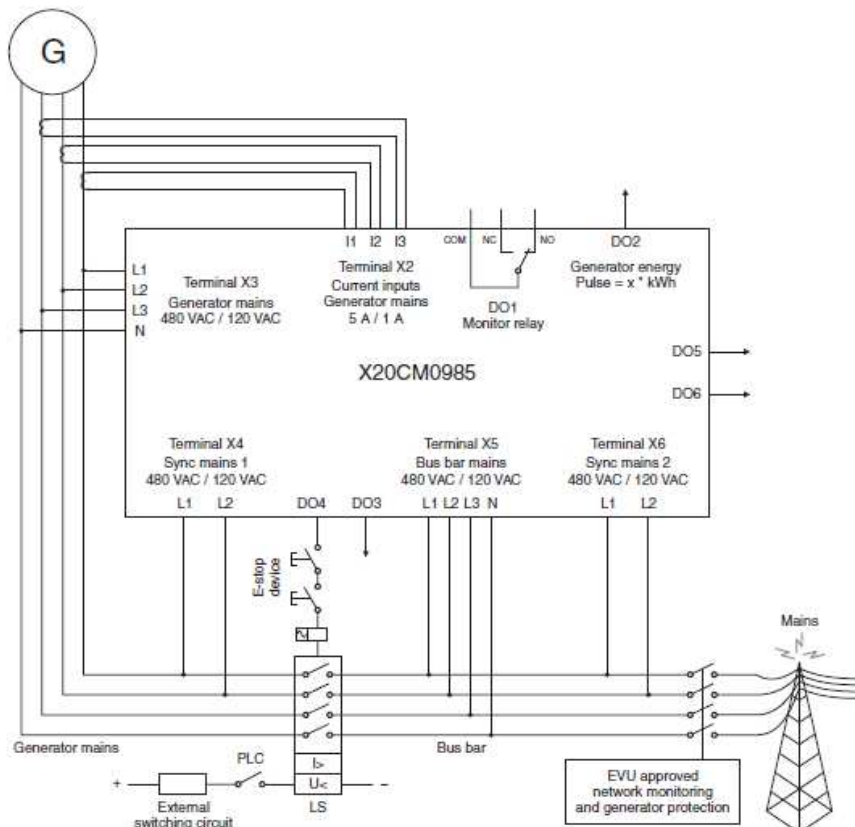

In the measurement unit, the three current inputs are suitable for both X:1A and also X:5A

current transformers. The excellent overcurrent resistance as well as the high resolution of the measurement unit round off the features. For the voltage inputs, the value range can be configured between 480 VAC and 120 VAC.

The area of use includes 4-wire AC networks with a phase voltage up to 480 VAC and 3-wire systems, whereas L2 can be grounded (V-connection). The module can also handle an Aron measuring circuit.

The resulting measurement values range from pure phase current and phase conductor/line voltage to active current, reactive current and apparent power components, mains frequency, power factor and much more. Additionally, peak values and work counters are saved on the module in nonvolatile memory. Depending on the configuration, a digital output with scalable rating can also be used as pulse encoder for an external energy meter.

The synchronization unit not only takes the phase position and phase voltage into consideration, built-in intelligence also takes the change speed and other parameters into consideration and allows them to influence the decision for switching the synchronization output. Monitoring of a generator is possible with a large number of additional conditions. A total of four voltage inputs provide the needed flexibility.

Monitoring functions extend the features of the module. Rating-dependent over-current monitoring is included, which uses the thermal capacity of the motor/generators to allow short overloads and still provides full protection. Dependent delayed unbalanced load monitoring, which is used to protect three-phase producers and three-phase networks from an unbalanced load, can be adjusted to the characteristics of different generator types using parameters while taking its special thermal time constants into consideration.

Protection integrated into the turbine software:

- Temperature Protection (stator, bearing, winding)
- Over/Under Voltage Protection (ANSI 27/59)
- Over/Under Frequency Protection (ANSI 81)
- Overspeed Protection (ANSI 12)
- Overload Protection
- Equalizing Current Time Protection
- Out-Of-Balance Protection (ANSI 60)

- Protection against too Low-Excitation (ANSI 40)
- Protection against Reversed Power Flow (ANSI 46)
- Stator Grounding Protection -> Option (ANSI 64)
- Protection against Generator Differential Fault -> Option (ANSI 87)

2 Low Voltage Switch Syst.

The entire low-voltage switch system is installed in capsulated cabinets

Switchboard	400,00 V
--------------------	-----------------

Electrical characteristics

Rated voltage	V	690	
Service voltage	V	400	
Rated frequency	Hz	60 Hz	
Rated insulation level (one min. 50 Hz withstand voltage)	kV rms	1	
Surge category	CAT	III	
1 second withstand current	kA rms	65	
Peak withstand current	kA peak	187	
Busbar rated current	A	200	

Cubicles for 400V Low Voltage Switch System

Item	Type	Name	Switchgear Name	Substation Name	Quantity
1	CB	INCOMING CUBICLE	CB1		1
2	CB	AUXILIARY CUBICLE	CB2		1
3	CB	GENERATOR OUTGOING CUBICLE	CB3		1

Cubicles for 690V Low Voltage Switch System (when using a 690V Generator)

Item	Type	Name	Switchgear Name	Substation Name	Quantity
1	CB	INCOMING CUBICLE	CB1		0
2	CB	GENERATOR OUTGOING CUBICLE	CB2		0

* When using a Generator with higher voltage than 1000V it will be fed into the Medium Voltage Switch System

Scope of Supply for Low Voltage Switch System

3 LV switch system cabinets

with the dimensions: 1000x2000x600 mm

Make: SEAMTEC

Type: TS 8

Protection class: IP 21

following components are included into a switching cabinet:

400/690V-distribution:

- 1 incoming circuit breaker NSX160
- 1 5-pol bus bar
- 3 current transformers 100/5 A Kl. 0,5
- 6 NH-switch with fuses
- 1 voltage protection device
- 1 clamps and accessories
- 10 3-pol. branches with auxiliary contacts



3 Main Power Transformer (Oil Transformer)

0 power transformers with following characteristics:

- Rated power output (max.)	100	kVA
- Rated voltage at primary side	---	kV
- Rated secondary voltage	0,4	kV
- Rated frequency	60	Hz
- Vector group	Ydn5	
- Maximum ambient temperature	40	°C
- Impedance voltage	4	%
- PK (Short-circuit losses @ 75°C)	2,0	kW
- P0 (No-load losses)	0,3	kW
- Weight (Transformer + Oil)	1460	kg
- Dimensions (LxWxH): ~	1200 x 720 x 1530	mm
- Hot Dip Galvanized (if by the sea)	Option	NO € 0
- Buchholz Relay	Option	NO € 0



Prices of transformer will change accordingly.

3a Aux. Unit Transformer (Oil Transformer)

0 power transformers with following characteristics:

- Rated power output (max.)	100	kVA
- Rated voltage at primary side	0,4	kV
- Rated secondary voltage	0,4	kV
- Rated frequency	60	Hz
- Vector group	Dyn5	
- Maximum ambient temperature	40	°C
- Impedance voltage	4	%
- PK (Short-circuit losses @ 75°C)	2,0	kW
- P0 (No-load losses)	0,3	kW
- Weight (Transformer + Oil)	1460	kg
- Dimensions (LxWxH): ~	1200 x 720 x 1530	mm
- Hot Dip Galvanized (if by the sea)	Option	NO € 0
- Buchholz Relay	Option	NO € 0



Prices of transformer will change accordingly.

WWS uses leading European transformer brands with high efficiency.

Manufacturer: GBE - Italy, SBG - Germany, BARTH - Austria etc.

General Characteristics:

- Design according to IEC60076 & ÖVE EN60076
- Hermeticism Design
- Oil filler neck & drain plug accor. to DIN42553 & 42551
- Protection Class IP54
- Ambient Temperature: -25°C to +40°C

Included Equipment and Accessories:

- Cooling: ONAN
- HV & LV feed through made of Porcelain
- Mineral oil according to IEC60296 class 2
- Dial thermometer: 0 - 120°C
- 5-step diverter: operateable in powerless state

4 Med. Voltage Switch Syst. --- kVA

Switchboard --- kVA

Make: Schneider Electric - AUT; Driescher Wegberg - GER

Type: Flusarc 36, RM24, MINEX; GISELA

Electrical characteristics

Rated voltage	kV	---
Service voltage	kV	---
Rated frequency	Hz	60 Hz
Rated insulation level (one min. 50 Hz withstand voltage)	kV rms	70
Impulse withstand voltage (1.2/50µs wave)	kV peak	170 up to 1000 m
1 second withstand current	kA rms	16
Peak withstand current	kA peak	40
Internal arc withstand current (IEC 60298 app. A)	kA rms	16
Busbar rated current	A	--



Switch Cabinets & Cubicles for Generators 400V & 690V (Voltage below 1000V)

Item	Type	Name	Switchgear Name	Substation Name	Quantity
1	NE-DI	Compact Switchgear: Circuit breaker & cable outgoing cubicle	+A1		1

Switch Cabinet & Cubicles for 6,3kV Generators

Item	Type	Name	Switchgear Name	Substation Name	Quantity
1		Generator Cubicle	-		0
2		Auxiliary Cubicle	-		0
3		Meter / Measurement Cubicle	-		0
4		Outgoing Cubicle	-		0

Total quantity of cubicles necessary for medium voltage switch gear: **1** Cubicles

Size per Cubicle (BxHxT): ca. 600mm x 2000mm x 1100mm

General Characteristics:

- Metal-enclosed, air insulated switch gear
- SF6 gas-insulated switchgear for medium voltage power distribution up to 36kV
- It is designed for secondary substations on a ring or radial network of energy distributors and for wind-, water-, and photovoltaic power.
- Featuring gas insulated technology for an extended service life and very low maintenance costs even in harsh environments.
- The system offers a wide range of functions based on switch-disconnectors, vacuum circuit breakers, switch disconnector fuse combinations, earthing switches and metering units.
- The panels are designed for indoor installation
- The design of the panels corresponds to the specification of the IEC 62271

5 Battery Syst. & DC distribution 24V

Battery system for emergency operation of turbine control system with automatic charger, load control system and safety system.

Batteries:

1 battery system 24 V with maintenance-free lead batteries installed on a rack

Life time 10 years

Capacity 45 Ah

Charger and distribution

Regulated charger according to U-I-identity line

nominal current 20 A

24 V-distribution

- 1 DC distribution system with branches, protection systems, power and voltage display
- Decoupling Backup UPS Module
- Fused circuit breaker for the supply of the control panels

6 SEAMTEC SCADA Basic System (Supervisory Control And Data Acquisition - System)

Make / System: SEAMTEC SCADA

SEAMTEC SCADA System is a high tech - modular SCADA System and is optimized specially for hydro-power plant operation. The single control-entities are connected through the network and interact directly with the SCADA System. The system is based on a state of art high tech .NET Webapplication

Languages:

The system has multi-lingual-ability and can be used in desired language.

(German, English, Spanish, Russian, Rumanian, Turkish)

Protocols

- risk report protocol
- operation protocols (day, month, year, ...)
- hardcopies

The following functions are provided:

- Machine start
- Machine stop
- Choice of operating mode
- Adjustments of desired values (chosen values)
- SMS/E-Mail information and part-operation device -> Option
 - a) all Alarms are sent via SMS or/and E-Mails to maximal 5 numbers/adresses
 - b) you can confirm a Alarm with a PIN-Code, and if Problem is solved - the turbine will start automatically
 - c) you can check important values like: Power, water levels, openings,... via SMS or/and E-Mail

Images:

- First image
- Electrical overview with measured values
- Mechanical overview with measured values
- Overview water management (weir, pipeline, power house, ...)
- Temperatures
- Alarms
- Maintenance intervals -> Option
- Curves (values to be selected)

Archives (about 30 values)

- report recording (operating mode, opening positions, regulation parameters,...)
- Measurement recording (Power, Energy, Temperatures, Water levels,...)

All values are saved minute-by-minute within the first 24h.

After the first 24h every 15 minutes an average value of the last 15 minutes will be calculated and stored.

Additional to the 15 minutes average all atypical values are saved.

All values can be exported into a (excel-) file for further using.

Licences

All required licences (Microsoft license for server and workstation as well as SEAMTEC SCADA software license) are included.

Interface/gateway:

For interface of a external database management system there exist a OPC or a MODBUS interface -> Option

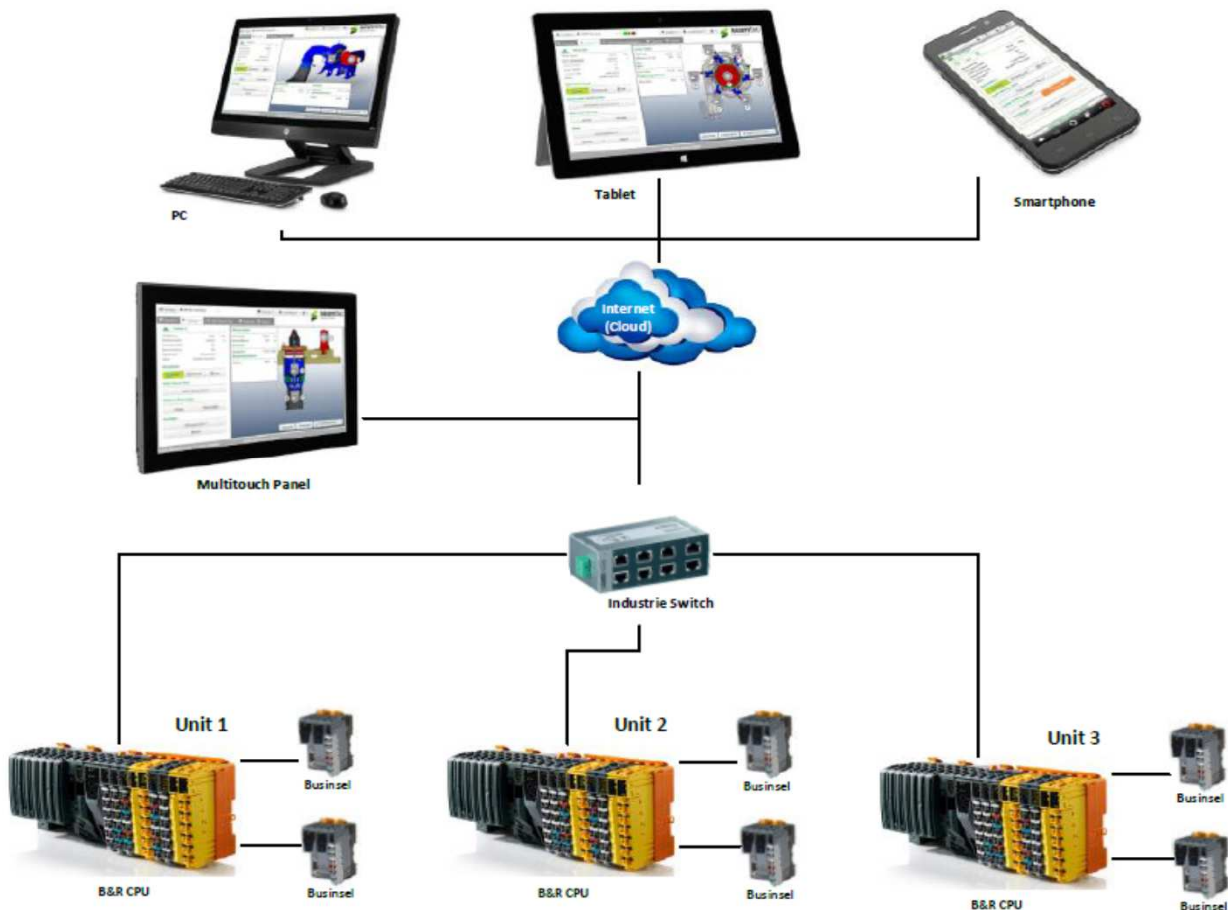

7 Fault Message Service

In case of an failure or warning a short text message can be sent up to 10 tepephone subscribers or cell-/smart phones. For this feature the system has to be connected to an internet access in the power house.

Note:

The DSL-Router for internet access in the power house has to support the following features:

- Port Forwarding (Port TCP80, TCP8060, UDP500, UDP4500)
- VPN (IPSec) Protocol

Another requirement is a fixed public IP-Address (IPv4) for remote access.

If the bandwith is below 512kb/s, or the signal is noisy, a proper operation or huge data transfer cannot be guaranteed therefore a high bandwidth data access is recommended!

8 Remote Operation

Combined with a digital turbine control system. In SEAMTEC SCADA System, an external access can be integrated. The Client only needs an Internet Browser (actual standard versions, e.g. IE11, Google Chrome). The remote access to the power house will be established over a VPN tunnel. This VPN tunnel provides a secure access between client and power house. With a remote control the machine can be managed and supervised via an external Client (e.g. laptop, tablet pc, smart phone) anywhere in the world als long as a stable internet connection is established.

9 Power Cable Set and Cable Trays

Cable Length: 10 m

Type: Will be determined after exact cable length and generator power are determinde

Including generator power cables from the generator to the low-voltage, medium-voltage switch system or transformers. The standard prize includes a cable length of 10m unless mentioned differently and needs to be elaborated exactly to submit a final offer. Cables are designed to transmit and withstand the max. load currents and power peaks. This also applies for all cable trays which are necessary to securely place the cables between the units.

10 Engineering & Documentation

Detailed electrical engineering and design of all circuits, switches and wiring as well as a documentation of all the electrical equipment implemented.

Documentations (2 series) consits of:

- 1-poled schematic
- Switchboard Diagram
- Circuit Diagram
- Equipment List
- Clamp Plan
- Cable List
- Release Diagram (protection)
- Description of the equipment
- Program Documentation (plc)
- Service & Operation Manual

Schematic Single Line Diagram:

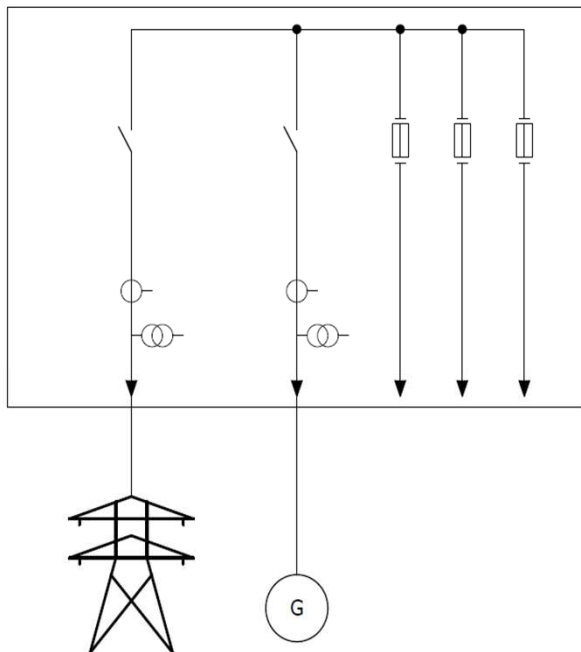

D Erection & Training

1 Erection on site

The erection is performed by WWS Wasserkraft personnel. The usual installation team consists of 2 mechanical engineers and up to 2 electrical engineers depending on scope of delivery. Our engineers are highly trained staff, having longstanding experience in the erection of hydro power plants and contributed to finish the work according to schedule. At least one of our workers will speak and understand appropriate English. Our workers will be equipped with basic hand tools and safety protection. Erection is made according to agreed time schedule which should include concreting and all other activities out of our scope that could affect the erection. All lifting devices need to be available according to schedule and during the defect liability period.

2 Commissioning and Training

The commissioning of our scope of supply is carried out by one mechanical engineer and one electrical engineer. The purpose of the commissioning is to check that all equipment supplied by WWS Wasserkraft is working properly and without defects. During this period all functions are tested and all alarms and events of the control system are carried out in the right way.

Training of customer and operators of the plant takes place during erection of the plant and during commissioning. This way the customer's staff will get already intense practical experience and time to get familiar with the system. In addition to the training during erection and commissioning we consider to 2-4 more days of training (as agreed) when the turbine is able to be started up and main work is finished.

3 Travelling Costs

Estimated expected costs for travel time, travel costs as well as flight tickets for installation time during a single phase installation. Accommodation for WWS workers will be arranged by customer.

E Packaging & Transport

Standard commercial purpose packaging (not using special packaging material as for example IPPC-Standards ISPM15; etc) of all parts and equipment listed in the scope of supply, loaded and fixed on the truck, trailer or container to assure a safe and protected delivery of the product to the specified site.

Transport, if carried out by WWS Wasserkraft will be according to the ICC - International Commercial Terms using the **Incoterms® 2010** clause:

CFR – Cost and Freight (named port of destination)

Seller must pay the costs and freight to bring the goods to the port of destination. However, risk is transferred to the buyer once the goods are loaded on the vessel. Insurance for the goods is NOT included.

F Optional Equipment

1 Inlet Pipe

Length:	L=5000 mm	(Pipe Length)
Diameter 1:	--- mm	(Diameter of Penstock)
Thickness:	#NV mm	(Thickness of the material of the pipe)
Pressure Group:	PN 6	

Inlet pipe made of construction steel and hot dip galvanized. Customized design to have transition free connection between penstock and turbine intake. With flange connection on both sides according to EN1092-2. Bolts and nuts made of stainless steel. Outside coating with RAL industrial epoxy paint.

2 Bypass Valves (Plunger Valve)

To reduce water hammer effect in emergency situation. When inlet valve performs an emergency shut-off, the bypass valve opens up immediately and eliminates the risk of pipe burst. Opening by counterweight, closing by hydraulic cylinder. Incl. 2 limit switches and throttle valve to regulate opening and closing time.

Make: Falkner Valves - AUT; VAG - AUT; ect.

Product features and benefits

- Face-to-face length acc. to EN 558-1
- With flange ends on both sides acc. to EN 1092-2
- Control valve in straightway type
- With customized control device depending on operating conditions (manual, hydraulic, motorized)
- Low actuating torque due to pressure balanced valve piston
- Rotationally symmetrical flow guidance
- Axial movement of the plunger by means of crank gear mechanism
- Elastic profile sealing ring located in the no-flow zone for high durability
- Wear- & corrosion-resistant and infiltration-proof piston guides in the body by micro-finished bronze weld overlay

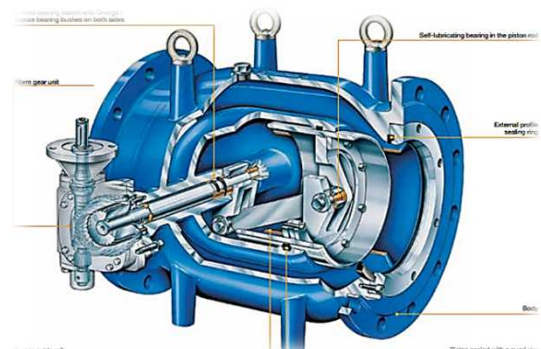

Material

Body: Ductile cast iron EN-JS 1030 (GGG-40)
Piston guide rails: Bronze overlay welded
Piston: Stainless steel 1.4301
Valve sealing: EPDM
Inner parts: Stainless steel
Bolts: Stainless steel A4 (DIN EN ISO 3506)
Bearing bush: Bronze
Corrosion protection: Inside and outside epoxy coating

3 2nd Pump unit for HPU

Current: **DC**
Voltage: **230V**

Second pump unit for hydraulic power aggregate to secure operation even when first pump unit errors out to maximize reliability of hydro power plant. Voltage and current selected according to customers needs.

4 Humidity Absorbing Filter for HPU

Make: **EATON**
Type: **BFD**

The filter prevents the penetration of contamination from the ambient air in the hydraulic fluid. The circulating air contains particles and moisture that can cause corrosion, increase equipment wear, and reduce fluid performance. This humidity absorbing vent filter for hydraulic power units protects expensive hydraulic equipment from , raises reliability and reduces maintenance costs simply by:

- Preventing corrosion
- Prolonging the lifetime of hydraulic lubrication fluids
- Minimizing downtime, repairs and wear
- Extending the lifetime of regular oil filters

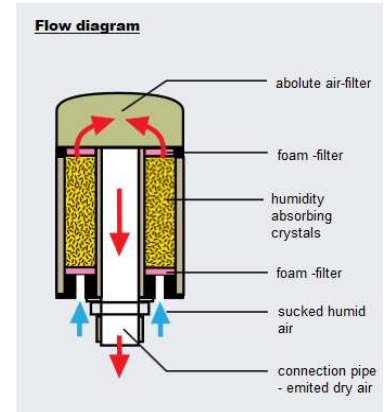

5 Proportional Valves for HPU

Make: Parker, Festo

Instead of regular valves for the HPU, electrical regulated and programmable proportional valves will be used. All electronic controller and wiring are included.

Technical features:

- Low hysteresis
- High reproducibility
- Load-independent oil flow
- 5 flow rates

6 Biodegr. Oil for HPU

Make: Panolin HLP SYNTH E

Based on saturated esters from natural resources combined with special additives. Fully synthetic and rapidly biodegradable high-performance hydraulic fluid.

Eco-Labels

PANOLIN HLP SYNTH E fulfills requirements as in:

- European Eco-Label
- Dutch Vamil Regulations – VROM
- Swedish Standard
- US Bio Preferred



7 Grease Pump f. Sealings

Make: LINCOLN Quicklube©
Current: DC
Voltage: 24V

Lincoln Quicklube centralized and automatic lubrication systems
A automatic greasing pump has the advantage to constantly pump the required amount of grease to the sealing, instead of a daily or weekly peak. In addition a maintenanceless operation is ensured (refilling only every 4-8 month).

These pumps are electrically operated and are used in progressive-type automated lubrication systems. The proven and reliable P203 pump has been designed to develop high operating pressures allowing it to supply NLGI #2 grease in most ambient temperatures. Versatile, compact and economical, this pump can be enhanced with several options including an integrated controller, low-level monitoring and system monitoring.



8 Wicket Gate Monitoring

Electrical monitoring system for wicket gate position. Each guide vane is equipped with a sensor and adjusted to the correct position. If a guide vane gets misplaced for example due to piece of debris the sensor contact opens up and immediately an alarm is displayed notifying operators to correct the issue also showing the number of the guide vane to exactly identify the failure at the machine. This way plant reliability can be increased as efficiency will not be interrupted due to incorrect wicket gate adjustment and unnecessary vibrations can be avoided.

9 Bridge Crane incl. Rails

The steel structure of the crane is in accordance with DIN 15018, Lifting class H2, Loading group B3 - calculated.
Designed as a box girder crane. Girder with two-sided slopes of 45° angle. The lower edge of the Crane girder is at the same height as the upper edge of the runway rail. The crane is designed for indoor operation in a factory hall similar building. Designed to be used at normal and ambient temperatures from -10 ° C up to max. +45 ° C. Crane with electric wire rope hoist, monorail hoist for low headroom method on the bottom flange of the crane girder.

Main lifting:	5,0 m/min 8,90 kW 40 % ED
Adjustment lifting:	0,8m/min 1,40 kW 20 % ED
Trolley continuously:	5,0-30,0 m/min 0,35 kW 60% ED
Trolley:	5,0/20,0 m/min 2x0,20/0,80 kW

Linkage: wired ground control moved the crane carrier
power supply: trolley power via trailing cable including grounding



Current: three-phase

Operating voltage: 400 V

Frequency: 60 Hz

Control voltage: 48V

Load control to protect the hoist from overload, type MGS, electromechanical mode of action.

Integrated load collective memory load spectrum.

Static calculation:

Will be performed according to needs and forwarded explicitly to the customer

Quality system certified to ISO 9001 - Permanent quality control

Brand: Demag Cranes & Components GmbH

10 SEAMTEC SCADA Enterprise System

The SEAMTEC SCADA Enterprise System is based on the SEAMTEC SCADA Basic System and is a professional solution for data acquisition programs that will support several new features and is recommended by WWS Wasserkraft to manage several hydro power plants from one workstation:

Additional Features: (Based on Basic Edition)

- Single Line Diagram of the entire plant with electrical data
- Extended Archive Functions (long term data saving and analysis with 6TB HDD)
- Energy Monitoring
- Optimized Hardware components for SCADA Enterprise System for 24/7 operation
- Power House ethernet network system to connect other PC's
- Internet Router for internet connection (Firewall function, VPN tunnel)

Scope of Supply:

- SEAMTEC SCADA Enterprise Edition License
- Workstation PC
- 24" LCD Display
- Color Inkjet Printer A4
- 19" Network Rack (min. 28 HE)
- 19" Switch (28 Port, 1Gbit)
- SEAMTEC SCADA Server (19" Rack)
- 150m Ethernet Cat6 cable
- Router

11 Condition Monitoring

Condition Monitoring simply increases plant availability and reliability.

The purpose of condition monitoring is to minimize machine down time due to error by noticing changes in the machine set or parameters in advance before they can lead to failure or breakage and respond with a preventive action/ maintenance accordingly. Therefore maintenance costs can be reduced and the production can be maximized. Mainly this can be accomplished by the implementation of sensitive sensors on the machine sets.

Sensor technology and state of the art electronics combined with complex mathematical logics and constant recording of the actual machine status enables the possibility to identify bearing failure, increased vibrations,

temperature rise and other changes in the condition in an early stage.

Advantages of Condition Monitoring:

- Machine components only need to be repaired or exchanged if really necessary
- Potential errors can be recognized at an early stage
- Due to the integration of Condition Monitoring into the operation process the reliability of the results and statements can be increased significantly.

Delivery includes:

- Condition Monitoring measuring card
- Vibrationssensors with 20m cable
- Software module for evaluation, implemented into the turbine software

12 Redundant CPU Solution

B&R's redundant control system concept ensures maximum availability for entire systems as well as individual machines, reducing down time and the involved economic losses as well as costs of repair. Master redundancy with POWERLINK synchronizes data with microsecond precision and can be switched over in a matter of milliseconds. This functionality is seamlessly integrated in the real-time operating system and extremely easy to use. A second identical Atom™ controller from the X20 standard product range is added to the existing control topology and configured as redundant via software. An interface module handles data exchange completely automatically. Configuration and visualization remain the same for the user. Maximum machine availability really is only a mouse click away.

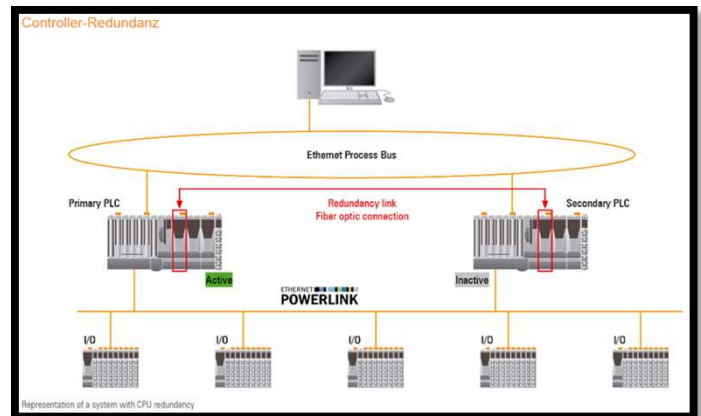

13 Monitoring Camera - Outdoor

2-Megapixel Day/Night PoE Outdoor Network Camera

Exceptional Image Quality

With built-in 3DNR (3-Dimension Noise Reduction) and WDR (Wide Dynamic Range) technology, the camera is able to filter the intense backlight surrounding a subject and remove noises from video signal. The result is that an extremely clear and exquisite picture quality can be produced even under any challenging lighting conditions.

Flexible Power Options

Featuring PoE (Power-over-Ethernet) capability, the device receives electrical power using Ethernet cabling from a PoE-PSE (Power Sourcing Equipment) device. Thus providing great cost savings by eliminating the need for additional power cables and outlets. In addition, this camera also supports power 12VDC/24VAC through an optional external power supply in case a PSE device is not available.

Free bundled 64-channel Management Software

The free IP CamSecure software allows you to monitor up to 64 IP cameras simultaneously on one screen to enhance scalability. For added convenience and flexibility, the software includes various advanced features such as scheduling recording, event alert, and much more. In addition, simply install our free iCamSecure App to your smartphone and connect to the PC with IP CamSecure software installed, you will easily turn your smartphone into a portable surveillance system for real-time monitoring and snapshot.



14 Camera Surveillance System up to 40 cameras

Standard Package: **3** Cameras

The Surveillance Station is a professional network surveillance Video Management System (VMS).

Live view:

Maintaining accessible and reliable live surveillance feeds is essential for properties such as retail stores, hotels, construction sites, offices, and at home. With the Surveillance Station, you can easily manage & monitor multiple IP cameras on a real-time basis through web browsers, and attain the first-hand status of monitored corners, such as building gates, office entrances, or emergency exits, safeguarding your staff and property.

Recording:

The Surveillance Station provides flexible options to set up IP camera recording, including video format, frame rates, schedules, smart recording, and more.

High quality codec recording:

The Surveillance Station supports H.264, MPEG-4, M-JPEG, and MxPEG recording, ensuring high-quality recording videos for future playback and reference.

Features:

- Smart recording
- Scheduled recording
- Alarm recording

Playback:

The Surveillance Station provides various ways for you to search and analyze recordings so you can efficiently look up the desired events.

Features:

- Intelligent Video Analytics (IVA)
- Real-Time watermarking

Management:

The Surveillance Station provides flexible options for you to set up a surveillance system that is fully customized for you.

Web-based user interface

The management of IP cameras is all done on the browser. With no additional software required, you save more time for other more important tasks.

Technical Data:

- 6 TB (HDD) (Raid 5)
- Intel Core Processor
- 4GB RAM
- 2 x 1GBIT RJ45 Ethernet Port

15 Weather Station

The weather station will give detailed information about the current hydrographic situation on site. Up to 4 temperature sensors can be implemented into the SEAMTEC Software such as room temperature, outside temperature and water temperature. Additionally all temperature data will be stored and the actual temperature value is visible in the graphical user interface. With the water temperature sensor it is also possible to activate trash rake and slice gate heating elements automatically. Furthermore a rain sensor is implemented to show actual precipitation on site. Another option is the integration of up to 8 smoke detectors into the turbine software.

Scope of Supply:

- 4 temperature sensors (2 indoor, 1 outdoor, 1 water)
- 2 smoke detectors (alarm integrated into control system)
- 1 rain sensor
- 15m cable per sensor
- Installation and commissioning

Features:

- Display of all temperature and precipitation values
- Digital storage of all data
- Report with data analysis

16 Additional Water Level Sensor

Piezoresistive Pressure Transmitter:

Make: Keller

These pressure transmitters are designed for level measurements where the highest accuracy is required.

This Series is based on the stable, piezoresistive transducer and a micro-processor electronics with integrated 16 bit A/D converter. Temperature dependencies and non-linearities of the sensor are mathematically compensated.

This probe is fitted with durable cable with an integral vent tube to the atmosphere.



17 Smoke Detector - Power House

Smoke Detector implemented into turbine control system. In case of smoke detection alarm will be triggered giving a loud beeping sound as well as a alarm will be displayed on the screen shutting down the machine and fault message will be send to mobile phone recipient. If implemented to local alarm system a direct information of the local emergency station such as fire fighting station can be send to minimize response time.



18 Electrical Installation - Power House

Includes the complete inhouse electrical installation for the power house, such as light, power sockets and light switches. To calculate working effort for our electricians a drawing of the power house including electrical specifications and quantitie of switches, power sockets, light sources and cable length needs to be specified in advance.

19 Ventilation System - Power House

Standard ventilation exhaust to purge air into the power-house and thereby remove excess thermal energy from generator and other heat inducing machine components. Not designed to cool the powerhouse lower than outside temperature. Designed for continuous operation.

Flow: 3800m³/h

Power: 240W

Temperature: -35°C to +40°C

Noise level: 75dB/1m



20 Temperatur Sensor - Power house

PT100 Indoor Temperatur Sensor implemented into control software. Including wall mounting and vented housing for accurate temperature reading. For indoor use only. Temperature range 0°C to 70°C. Accuracy according to IEC 751 class B

21 Generator Neutral Cubicle

Neutral Grounding Resistors are used in order to limit maximum fault current to a value which will not damage the equipment in the power system, yet allow sufficient flow of fault current to operate protective relays to clear the fault. Although it is possible to limit fault currents with high resistance Neutral Grounding Resistors, phase to ground short circuit currents can be extremely reduced. As a result of this fact, protection devices may not sense the fault. Therefore, it is the most common application to limit single phase fault currents with low resistance Neutral Grounding Resistors.

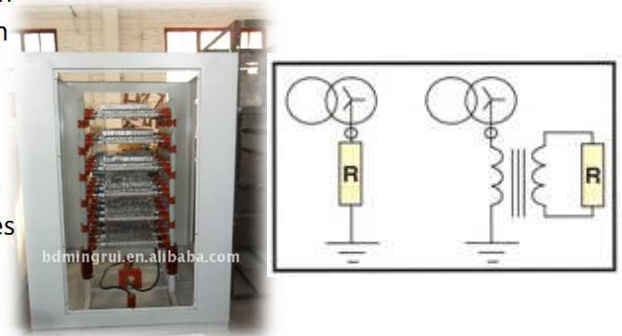

23 Diesel Generator

Emergency diesel generator set 59,8 kVA with DEUTZ diesel engine 1500 rpm
Model: DEUTZ GSL 65D - stationary execution, sound-dammed in accordance with CE standard, with switchbox for manual and automatic operation

Engine: EUTZ BF4M 2011C - oil cooled 4 in line cylinders diesel engine

Generator: brushless exciter design with solid state

Synchronous Generator: **60 kVA**
Continuous Output: **60 kVA** **48kW** at $\cos(\varphi)=0,8$
Supply Voltage: **400V** (230/400V or 208/480V)
Frequency: **60 Hz** (50 or 60Hz)
Dimensions (LxBxH): 2285 x 920 x 1150mm
Weight: 1093kg
Capacity fuel tank: 90l



24 QA/QC Protocol for all equipment

Complete Quality Assurance and Quality Control Protocol from WWS Wasserkraft manufactured parts as well as from all parts delivered by subcontractors (such as generator, bearings, pumps ect.). A comprehensive audit record including testing protocol, measurement protocols, test certificates, testing procedures, tolerances of all parts and showing part standards according to DIN, EN, ISO ect. to assure highest quality standards of our products.



25 Fly-wheel I (GD2) = unknown

Fly-wheel will reduce the speed increase in case of emergency stop.

In addition it is a MUST for island operation. With the additional rotating mass a the production system remain stable, even a big consumer is switched in the energy consumer system. In such cases, the flywheel stores energy when torque is applied by the energy source, and it releases stored energy when the energy source is not applying torque to it. The size of this fly-wheel have to be designed according the biggest consumer, which can switch into the consumer-system.

26 Separate shaft and bearings Roller Bearing

A separate turbine shaft and 3 separate turbine bearings (2 radial and 1 axial) allows to use a simply normal standard generator with less costs and shorter delivery time. On the other hand, it have to be considered, that the turbine house will be bigger and a additional bearing - which might be a reason for a additional failure or higher spare parts costs.

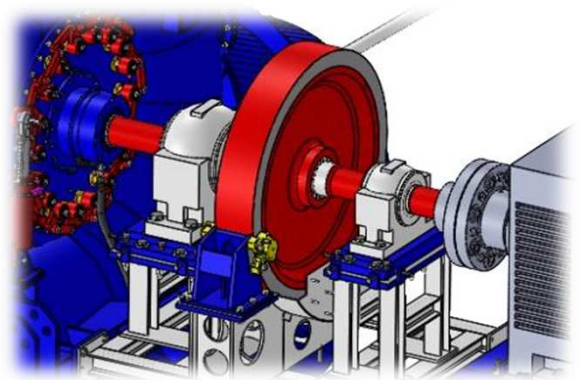

27 Elastic Coupling

In case of a separate turbine shaft and separate bearings a elastic coupling for transmission of the torque and the power from the turbine drive chain to the generator drive chain. The elastic coupling is needed to compensate potential imprecision or tolerances.



G Spare parts

1 Spare Parts Turbine / Main Valve

- 1 seal kit
- 1 set gaskets and seals
- 1 shaft sealing element
- 1 clamping set for each type which are used
- 1 set replaceable seals for butterfly valve actuator
- 1 set position transducers
- 1 set greasing for sealing
- 1 pc. Clamping torque for each installed type

2 Spare Parts Generator

- 1 Voltage regulator with power factor regulator
- 1 set fuses, rectifiers and varistors
- 3 pc. bearings
- 1 filling grease for one year
- 1 shaft sealing element
- 1 set PT100 sensors for bearings
- 1 set PT100 Sensors for windings
- 1 pc. Speed sensor

3 Spare Parts (Governor, Hydraulic power unit)

- 2 set of oil filters for one year
- 1 set of seals for each used typ of actuator
- 1 emergency closing valve
- 1 control solenoid valve
- 1 pressure sensor
- 1 oil level sensor
- 1 filling used oil
- 1 bubble for pressure accumulator
- 1 set sealings

4 Spare Parts Electrical Equipment

- 1 water level sensor
- 1 surge arrester
- 1 mains circuit breaker
- 1 multifunctional power meter
- 1 generator circuit breaker
- 1 auxiliary contactor
- 1 protection, metering and synchronization relay
- 1 differential protection relay
- 1 contactor
- 1 battery charger
- 1 multipanel touchscreen
- 1 PLC CPU
- 1 micro memory card
- 1 digital input/output modules
- 1 analog inputmodule
- 1 Ethernet module/switch
- 1 isolating converter
- 1 synchronoscope

H M & S Package

1 Maintenance Contract

- Verification of all fittings are tight
- Testing of storage (vibration measurement, running noise)
- Removal of old grease from the sealing
- regreasing with original grease
- replace of all necessary wear parts (f.e. sealings, ...) - original WWS Wasserkraft wear parts® included in price
- Leak Check and lubricate
- readjusting of the mechanical mechanism (wicket gate, ...)
- Wheel control cylinders checked for concentricity and tightness, adjust as necessary
- Check the runner and the adjustment parts for wearing and analyses the water

Generator:

- Check the smoothness
- Remove old grease from bearings and regrease
- Check the screws
- Check the cable connections are secure
- Check cooling system

Hydraulic power unit:





- test of hydraulic power unit
- Changing of filters
- check the oil quality and if necessary change oil (without import tax of oil)
- Check the pressure accumulator (nitrogen filling if necessary)
- All fittings and pipes for leaks
- Valve functions (emergency shut udgl.) Control

Electrical equipment

- funktion test of electrical equipment and if necessary changing of defect parts
- adjusting of parameters according expirience

2 Service Package Standard

only in combination with a maintenance contract

-  in combination to a maintenance contract **one additional year warrenty** (maximum 5 years)
-  maximum **192h** after written claim for an deffect start **reparation** in warrenty chase
-  free of charge **service hotline** from 07:00 till 18:00, Monday till Thursday
-  **remote controll support** from 08:00 till 16:00, Monday till Friday

3 Service Package Premium

only in combination with a maintenance contract

- 👍 in combination to a maintenance contract **one additional year warrenty** (maximum 5 years)
- 👍 maximum **120h** after written claim for an deffect start **reparation** in warrenty chase
- 👍 **24h service hotline**
- 👍 **yearly update** of software-source code
- 👍 **remote controll** support from 07:00 till 18:00, daily

4 Service Package All Inclusive

only in combination with a maintenance contract

- 👍 in combination to a maintenance contract **one additional year warrenty** (maximum 5 years)
- 👍 maximum **72h** after written claim for an deffect start demounting or **reparation** in warrenty chase
- 👍 main **spare parts** stored at WWS Wasserkrafts warehouse
- 👍 **24h service hotline**
- 👍 3 weeks/year **operating** of the plant (f.e. during illnes or vacation)
- 👍 **loss of profits insurance with a maximum of 2.100 EUR/anno**
(starting after 120h from written notification of the failure)
- 👍 **yearly update** of software-source code and saftey update
- 👍 **remote controll** support from 07:00 till 18:00, daily

V TURBINE MEASUREMENTS (preliminary)

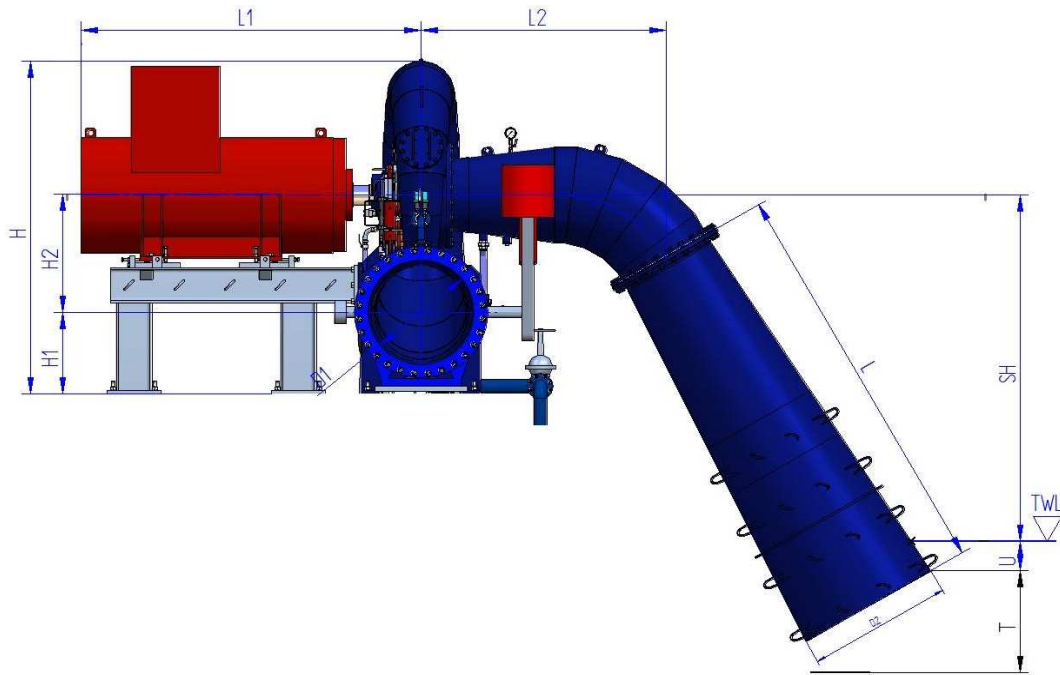

LR ϕ =	525	mm
H =	2370	mm
H1 =	500	mm
H2 =	950	mm
L1 =	2630	mm
L2 =	1840	mm
L3 =	1740	mm
SH =	---	m
U =	400	mm
T =	1600	mm
D1 =	700	mm
D2 =	1400	mm

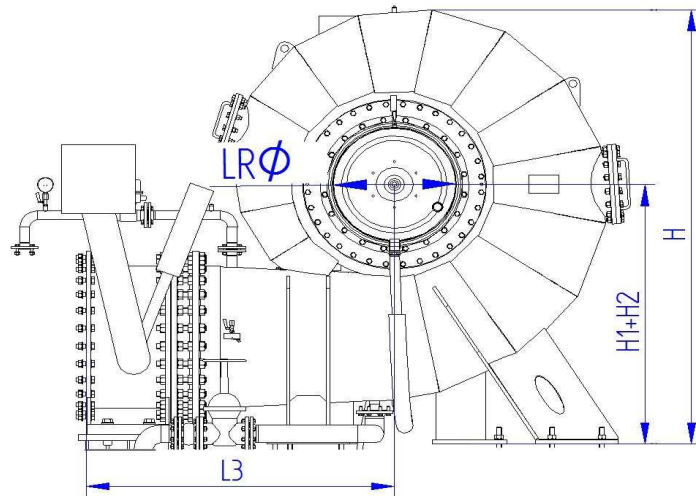

- LR ϕ Runner diameter
- H Total height of turbine housing
- H1 Height between bottom and inlet centre point
- H2 Height between inlet centre point and shaft axis
- L1 Distance of generator till vertical axis of runner
- L2 Distance of vertical axis of runner till draft tube elbow
- L3 Length of Inlet valve till runner centre
- SH Suction head: Height between horizontal runner axis and tailwater level
- U Approximate space between tailwater level and draft tube outlet
- T Distance between drafttube outlet and river bed
- D1 Inlet Diameter
- D2 Draft tube outlet diameter

VI TERMES OF PAYMENT

For 100 % of the Total Contract Price an irrevocable and confirmed Letter of Credit shall be opened and confirmed by a First Class Austrian Bank in favor of WWS Wasserkraft GmbH & Co KG on the agreed contract start date. For this WWS Wasserkraft GmbH & Co KG will submit a draft of an L/C.

Hence the payment will be made as follows:

40% of the Total Contract Price shall be paid in advance at sight against presentation of following documents:

- Down Payment Invoice stating 40% of the Total Contract Price

40% of the contract is due upon against presentation the following documents

- Commercial Payment Invoice stating 40% of the Total Contract Price
- Packing List
- Sender's copy of CMR

15% of the contract is due upon against presentation the following documents

- Commercial Payment Invoice stating 15% of the Total Contract Price
- Commissioning Certific
- In case the unfavourable circumstances stated in "Official Acceptance" last for more than three months, the final payment of 20% of the Contract Price automatically becomes due after the expiry of three months from the date of the freight document without the necessity of presentation of a Certificate of Commissioning or Provisional Certificate of Commissioning.

5% of the contract is due upon after 4 weeks test run

- Commercial Payment Invoice stating 5% of the Total Contract Price
- Final Commissioning Certificate (FCC)

If any additional works are necessary at site these shall be paid immediately after successful commissioning against presentation of the Invoice. The amounts of the payments are to be transferred immediately as the full amounts stated in the invoices without deduction of any fees. The Buyer will assume all bank fees regarding the opening and confirmation of the Letter of Credit as well as bank transfer fees.

VII TIME OF DELIVERY

The Contract comes in Force after the receipt of the downpayment and the Letter of Credit over the agreed
A detailed timetable will be agreed with the Employer. The below mentioned time of delivery serve as a rough
orientation:

<input checked="" type="checkbox"/>	8 weeks after receipt the down payment:	Installation drawings
<input checked="" type="checkbox"/>	12 weeks after receipt the down payment:	Jacket tubes for the conduits and recesses for concret works
<input checked="" type="checkbox"/>	10 month after receipt the down payment:	Installation Parts
<input checked="" type="checkbox"/>	12 month after receipt the down payment:	Turbine Generator and runner are ready for dispach
<input checked="" type="checkbox"/>	after below conditions:	Assembly work on site
	<input checked="" type="checkbox"/> After the date of delivery of undamaged equipment at site.	
	<input checked="" type="checkbox"/> Total erection of civil works are done as per drawings set,	
	<input checked="" type="checkbox"/> Manual crane in operation.	
	<input checked="" type="checkbox"/> Energy supply as: HV line charged	
	<input checked="" type="checkbox"/> Availability of water in the river (full or part flow up to 30 %	
	Works at site like assembling, installation and adjustment for the concrete works and commissioning: Start within 2 weeks after the Employer's written notification of when installation can begin.	
<input checked="" type="checkbox"/>	Finishing all wiring (including power cable), pipeline work and concret work	Commissioning and training

In case of unforeseeable circumstances or circumstances beyond the control of Contactor and its sub-suppliers, such as all cases of
force majeure, which impede compliance with the agreed period of delivery, the latter shall be extended in any case for the duration of
such circumstances; these include in particular armed conflicts, official interventions and prohibitions, delays in transport and customs
clearance, damages in transit, shortage of energy and raw materials, labour disputes, defective goods of a larger or important piece of
work, default on performance by a major sub-supplier or sub-contractor.

VIII CONTRACT CONDITIONS

CHAP. 1) SCOPE OF SUPPLY

The scope of supply is limited to the Contractor's scope mentioned in the Contract and the confirmation order. Supplies and performances are strictly limited to conditions and descriptions specified in present technical specifications and the general terms of contract.

CHAP. 2) DEFINITIONS

Contractor – WWS Wasserkraft GmbH & Co KG
Employer – Contract partner, which orders the Equipment
FAT – factory acceptance test (before delivery)
PMCC – provisional mechanical commissioning certificate (after
PECC – provisional electrical commissioning certificate (after installation)
PIO – putting into operation
CC – commissioning certificate (after PIO)
FCC – Final commissioning certificate (after the test run)

CHAP. 3) INTELLECTUAL PROPERTY RIGHTS

The copyright on the design of products and services making the object of present contract belongs to the contractor according to the law in force.

The use and exploitation of services provided by the contractor doesn't generate copyrights for the employer.

CHAP. 4) CONFIDENTIALITY - RECIPROCITY

The Contractor will keep confidential all information regarding the fulfilment of the objective.

The Employer will keep confidential all information stated in the technical documentations, procedures and technologies used by the Contractor throughout the validity of the contract.

The Employer and the Contractor will keep confidential all provisions stated in the offer and the contract.

(1) One contracting party isn't entitled, without having the written consent of the other party:

- a) to reveal the contract or any other provision stated in it, to a third party, besides those persons involved in fulfilment of the contract;
- b) to use the information and the documents obtained during the progress of the contract, in other purpose than the one of fulfilling its contractual liabilities.

(2) Revealing of any information to the persons involved in fulfilling the contract, shall be made confidentially, and will be extended only to those information required to perform the contract.

A contracting party will be exempted of liability for revealing the information regarding the contract, in case that:

- a) the information was known by the contracting party before being received from the other contracting party; or
- b) the information was revealed after being obtained the written approval of the other contracting party for such revealing; or
- c) the contracting party was legally bind to reveal the information.

CHAP. 5) WEIGHTS

The weights of the equipment and the shipment will be stipulated after the detail design work is done. Any indication of weight is not binding until release of the final installation plans. The heaviest weight indicated forms the basis for the dimensioning of the temporary hoists and the cranes necessary for unloading, heaving of the equipment into the relevant installation place and installation of the equipment.

The total weight of the plant and packing will be notified to the Employer. To neglect the weight of the plant and packing when received by the Employer is an omission of duties and all claims of any kind correlating to the weight are excluded.

CHAP. 6) QUALITY CONTROL - INSPECTION, TESTING AND TRAINING

Quality control, inspection and testing during the manufacturing, erection and prior to the commissioning of the plant, will be mandatory. All equipment is manufactured under strict European quality control procedures. The Contractor will carry out inspection and control of technical specification, designed parameters throughout the manufacturing of the equipments.

Before dispatch, the equipment will be examined by the Contractor and sent only after successfully passing the test. The examination procedure and the test schedule are to be provided by the Contractor at the time of signing of this Agreement. The tests carried out are to be notified to the Employer two weeks prior to the tests and the FAT should be dispatched to reach the Employer two weeks after the test. The Employer is free to participate at this tests at his own expense.

The following procedure will be applicable:

During the manufacturing:

The Contractor shall carry out the quality control and the examination in accordance with the Contractor's quality control practice and the quality control program.

During the erection /

The Contractor shall furnish the Employer with the usual erection and installation instructions and the relevant drawings in order to be able to inspect the shipment.

The Contractor will inform the Employer about finishing the plant and all parts and readiness for packing.

CHAP. 7) TRANSPORT AND LIFTING

The costs for transportation which are not covered by the terms of delivery (e.g. transport from the port to the installation site), temporary liftings and other equipment needed for the unloading of the truck at site and the heaving of the equipment into the relevant installation place have to be provided by and are to be borne by the Employer.

CHAP. 8) ASSEMBLING AT SITE

Equipment delivered by the Contractor to the place of delivery has to be transported by the Employer at his own expense to the site and is assembled by the Contractor according to technical specifications at the site. Before assembly the Employer shall install the working crane, necessary electricity for the site given due notice by the Contractor and finish the necessary construction work, so that the assembling of all units be performed at the same time or one after the other, without time interruption.

CHAP. 9) CONDUITS, GENERATOR EARTHING AND CONCRETING WORKS

All the following conduits are not included in WWS Wasserkraft's scope of delivery.

The Employer has to provide:

- three-phase current connection with zero wire needed during the installation
- chase, base and anchoring plates in the building construction according to WWS's details
- empty and protective pipes, channels and pits needed for the installation of the connecting and joining cables for the turbine, generator, governor, water level transducer, hydraulic aggregate etc.
- If the generator star point is need to be earthed to provide the protection required additional components and installation of same must be attended without any additional cost for the contractor.
- all power cables (if not ordered in point D7)

CHAP. 10) CONTRACTORS RESPONSIBILITY

The Contractor has to build the turbine corresponding to this contract to comply with all specifications predetermined by the Employer and by the administrative decision and all other official guidelines and regulations regarding construction and safety of the turbine. The Contractor is not responsible for the sound intensity of the turbine in service.

CHAP. 11) EMPLOYERS RESPONSIBILITY

The Employer is liable for all construction work and possible measures to comply the administrative decision regarding the maximum sound intensity of the turbine tolerated by the administration, the provision of national law and regulations. Claims of any kind regarding the sound intensity of the turbine are excluded.

The Employer is responsible for the safety and health of the Contractor's employees working on the site erecting and commissioning the plant. The Employer is liable to conduct all reasonable provisions for safety and health at the site. Especially the Employer is liable to protect the employees of the Contractor in case of rebellion, revolution, riot, armed industrial dispute etc. and has to guarantee a safe accommodation or departure to Austria.

CHAP. 12) INSTALLATION AND COMMISSIONING

WWS's engineers or chartered technicians required to carry out assembling, installation, commissioning, trial operation and training at site. The Employer is responsible for providing fullest support with two engineers, few technical officers, three skilled welders and ten unskilled persons to execute the erection, installation and commissioning works. The power supply must be present at the place of construction to ensure that the installation of all components within a train can be performed without interruption. The training of the skilled service personnel will be effected by the Contractor. Employer's Engineers will be present throughout the installation and commissioning. Any transport of our personnel and material in the country of the site have to be done and organized by the Employer.

The Employer has to provide normal hand tools needed to execute mechanical and electrical works. It is the Employer's obligation to provide temporary hoists, moving slides and other necessary equipment. Should special tools be needed, then WWS will make these available.

For the installation work it is essential to have all components supplied at the place of installation. The Employer shall give written notification of when installation can begin. The Employer is responsible that necessary building work is far enough advanced to permit installation to begin at the appointed time. It is indispensable that all conditions essential for the completion of the installation and commissioning works exist.

Alternative:

If, for reasons beyond the Contractor's influence (following listing only exemplary):

- consignment cannot be transported to or received at the site (powerhouse building not ready,...)
- installation and commissioning cannot begin within 60 (sixty) days from Contractor's notification that the consignment is ready for shipment
- installation and / or commissioning cannot be completed within 90 (ninety) days from a.m. notification

the following arrangement shall be made:

- the consignment is transported to the Port of discharge acc. to the Terms of Delivery
- the Employer has to arrange for storage at a warehouse / place of his choice at his own cost
- the balance amount for the equipment itself and installation and / or commissioning cost automatically becomes due after the period of 100 (hundred) days from the a.m. notification (i.e. cost not accrued are deducted from the Total Contract Value)

When the reasons for the unfavourable circumstances mentioned in above paragraph cease to apply, the Contractor shall as soon as possible fulfil his obligations according to the Contract; therefore a new time schedule shall be mutually agreed upon.

Any transport of our personnel and material in the country of the site has to be done and organized by the Employer.

The times and costs stated in the item "Installation and Commissioning" of the Contract are to be understood as guiding figures which can be reckoned with under favourable working conditions. Should the mentioned calculated periods not be kept due to unforeseen circumstances or due to poor and insufficient support given to WWS's supervisors, then the costs arising from the exceeded time will be calculated with rates mentioned under the paragraph „OPTIONAL COSTS“. In case of optional costs accrued these should be evidenced by protocols signed by the Employer and the Contractor (or his delegates).

CHAP. 13) CO- ORDINATION OF COMMISSIONING

The Employer has the responsibility to co-ordinate with the grid utility and make all the arrangements for commissioning. If there is any cost towards this the same has to be borne by the Employer. The Contractor will do only technical support like deputing expert for discussion if any.

CHAP. 14) OPTIONAL COSTS

In case of optional costs accrued the following day rates are valid for the costs of assembly, installation, training, commissioning and trial operation if proposed schedules for at site works are exceeded:

1 day rate for a mechanical engineer (for expatriate)	European Unit (EUR) 800,00
1 day rate for an electrical engineer (for expatriate)	European Unit (EUR) 900,00

The day rates are based on an actual working day of eight hours for five days a week, from Monday through Friday. For every hour overtime if the working period exceeds the eight hours working day a 50 % surcharge will be applied. For every hour overtime on Saturdays, Sundays and Holidays a 100 % surcharge will be applied.

The above mentioned rates include all labour costs. Travelling time is to be regarded as working time. Travelling costs for air tickets, train, bus or rent car and accommodation costs will be accounted for according to the actual expenses accrued supported by vouchers and documentary evidence.

CHAP. 15) OFFICIAL ACCEPTANCE

Immediately after termination of the mechanical installation, the consignment has to be accepted and taken over by the Employer by signing the PMCC.

Immediately after termination of the electrical installation, the consignment has to be accepted and taken over by the Employer by signing the PECC.

After PIO in connection with the take-over, a Certificate of Commissioning (CC) has to be drawn up. In case of minor defects, which cannot be amended on the occasion of supervision and which do not affect the efficiency, these have to be amended at a mutually agreed date between Contractor and Employer – without any unnecessary delay, but latest within the test period. In case of defects, which affect the efficiency, the Commissioning is deemed to be terminated only after amendment of these defects. All defects have to be noticed in the CC to agree on a mutual status. With the signature of the CC the Employer confirm to operate the equipment in the prescribed and cautious manner and accept some stop of operation to test the long-run operation and to adjust the high-tech equipment to a optimal operating status .

After the test run the FCC as to be drawn up, in which the parties confirm that the subject of the Contract satisfies the conditions in the Contract for take-over, and which states from which date the subject of the Contract is taken over and property thus passed to the Employer after the final payment of the contract price. The FCC shall be issued jointly by the Contractor and the Employer.

If the commissioning or agreed performance tests cannot be carried out within three months after signing the freight-documents, for reasons beyond the Contractor's influence, e.g. lack of water, grid problems, etc., the consignment has nevertheless to be approved and taken over by the Employer and a Provisional Certificate of Commissioning shall be drawn up and signed.

Both parties undertake the obligation to complete the performance tests within a three-month period from the date of the Provisional Certificate of Commissioning. In case the above unfavourable circumstances last for more than six months after signing the freight-documents or agreed performance tests cannot be completed for reasons outside one's control, the contract is deemed to be fulfilled.

CHAP. 16) DOCUMENTATION

Within eight weeks after opening of L/C and receipt of the Down Payment the contractor will submit outline drawings of the equipment to be furnished together with estimated weights, external forces, anchoring details and overall dimensions, to facilitate preparation of the structures into which the equipment is to be incorporated. The formwork and reinforcement plans must be prepared by the Employer.

As final documentation the contractor will submit operation manuals, spare part catalogues, workshop manuals, maintenance instructions, schematic wiring diagrams, general assembly drawings and sub-assembly drawings. The contractor shall furnish the employer with the usual erection and installation instructions and the relevant drawings.

In general the documentation is in English language. Some detailed descriptions might be written in German or other languages. Translations of documentation in other languages will be charged to the employer.

CHAP. 17) TRANSFER OF PERILS

The transfer of perils takes place according to the Delivery Terms stated in this contract. Upon arrival of the equipment at the port of discharge, the Employer takes all necessary measures to assure a perfect transport to the site or intermediate storing and subsequent transport of the equipment and particularly with regard to theft, damages caused, for example, by inclemency, humidity and/or fire etc. An insurance policy is taken out by the Employer covering delivered material, which is valued according to delivery note specifications. The Contractor will transmit to Employer before expedition, the values to be insured. The Employer must verify all material to ensure proper condition of delivered material and storage on site.

The passage of title will take place after payment of the contract price in full according to the terms of this contract.

CHAP. 18) RIGHT OF RETENTION

The Contractor is authorized to retain the whole plant or parts unless the Employer fulfilled his liabilities of the terms of payment agreed in this contract. The Employer must not deny his liabilities of payment in reference to the right of retention by the Contractor.

CHAP. 19) SAFETY PRECAUTION

The Employer shall provide free of charge for the contractor from the commencement of work on Site until taking over provide:

- (a) fencing, lighting and guarding of the Works; and
- (b) temporary roadways, footways, guards and fences which may be necessary for the accommodation protection and protection of owners and occupiers of adjacent property, the public and others."

In case of any damage based on a shortage of safety equipment, the Employer has to compensate all costs of the Contractor.

CHAP. 20) WARRANTY

Art. 20.1) General Warranty

All goods indicated in the scope of supply by the contractor are warranted to be free from defects in workmanship and materials and in conformity with the technical specifications provided in the present contract. The warranty period is 12 months from the date of commissioning or 14 months from the date of readiness of shipment which ever occurs earlier.

The employer has to inspect immediately the delivery and workmanship effected on its completeness and to check if these are free from defects. Possible defects and reclamations etc. shall be reported immediately to the contractor by means of a written list naming the defects in detail or else claims of any kind shall be excluded.

This warranty includes all supplied mechanical parts of the turbine including all items of electrical & control systems. The warranty applies solely to the arising faults which evidently fall under the contractor's range of responsibility. The employer must explain in writing technically-wise and clearly the reasons for request the application of warranty.

The warranty is not applied when instructions specified in the operation and maintenance manuals are not respected. Excluded from compensation is wear, improper treatment, maintenance which is effected inadequately or not according to the operation and maintenance instructions. No warranty is given for defects caused by improper installation in the event that the installation has not been executed by the contractor as well as in case of misuse, excessive use, insufficient lubrication, defects in the foundation or disregard of the contractor's instructions, or if third parties have executed repairs or made additions to the products. The warranty will not apply for any circumstances outside one's control.

Any technical faults arising must be corrected by the contractor in the fastest possible means. The warranty and/or compensation of damages are effected either by repair or replacement of the defective equipment or grant a reasonable price reduction, whichever the contractor chooses to do. The warranty is limited to the repair or replacement of damaged equipment at the place where made, or to repair in place equipment proven defective and does not cover consumables such as light bulbs, fuses, oils, lubricants nor all costs incurred to uninstall and/or reinstall the defective equipment as well as cost for transport (if truck is reachable with a 40t-standard truck).

The contractor is discharged from executing any warranty obligations for the time where either the equipment has not been taken over with a signed provisional or final Certificate of Commissioning or the Contract Price has not been paid in full.

Art. 20.2) Efficiency and output guarantee

The efficiency values and the outputs, given in the technical specification are guaranteed according to the relevant IEC-Regulations 60041 of "Field acceptance test to determine the performance of hydraulic turbines, storage pumps and pumps-turbine."

As per IEC-Regulations 60041, the employer and the contractor can agree mutually, if required, on one of the prescribed methods to measure the performance of the equipments. The tests must be carried out within the term of the guarantee and must be arranged and paid by the employer. In case of dispute, both parties have the right to refer to the applicable clauses of the relevant IEC-Regulations. A simplified measuring method can be arranged between the employer and the contractor. In case of doubt both parties have the right to consult the relevant IEC-regulations.

The performance of the equipment shall be measured by mutually agreeable methods. If performance tests are to be conducted by a third party the employer shall bear the cost for the tests. The third party shall be nominated by mutual agreement. In case the efficiency fall short, measured by the method accepted by both parties also after deduction of a measuring inaccuracy of 3 %, the contractor has the obligation and right , within the guarantee period, to carry out all required and possible modification to meet the agreed performance. Thereafter, and if the contractor is not able to rectify the problem within two months, the employer has the right to demand a penalty of 1 % of the contract price for each fall short percentage of the middle arithmetical efficiency of the guaranteed limit range of admission. However, if, due to generation losses, the Employer decides to do the rectification in a month suitable to the Employer, the Contractor has to arrange the rectification during that time. In this case maximum time permitted for rectification is limited to one and half years. The Employer has the right to refuse the turbine in case the percentage of efficiency fall short is more than 5 %. In case of refusal of turbine the Employer has the right to retain the turbine set until such time a new set is supplied/obtained.

In case the efficiency test shows that the guaranteed efficiency is under-run, the costs for the test will be divided proportionately according to the percentage of deviation between the Employer and Contractor, whereby 5 % deviation are equal to 100 % of the expenses.

Art. 20.3) Cavitation guarantee

The runner will be guaranteed against deterioration due to cavitation for a period of 8000 hours of operation or two years after commissioning of the turbine, whichever occurs first, as long as the runner has been operated within the designed limits.

The cavitation pitting evaluation will be made in accordance with the relevant IEC-Regulations 60609 "Cavitation pitting evaluation in hydraulic turbines, storage pumps and pump-turbines".

Erosion or damage caused by solid particles or sand and corrosion caused by aggressive chemical substances in water or by galvanic or electrolytic action do not fall in the cavitation guarantee.

Under this guarantee the contractor undertakes to repair the resulting damages. All areas where the depth of pitting exceeds 3 mm shall be restored to their original contours by welding with stainless steel and grinding to the damage a smooth surface equal in finish to the adjacent undamaged areas. After repairs of cavitation the contractor agrees that the pitting guarantees are renewed from the date the employer agrees that repairs have satisfactorily been completed. In case of local cavitation damage caused or aggravated by any contour errors, the contractor shall make the modifications necessary in the turbine parts to prevent its reoccurrence.

CHAP. 21) PROVIDE SERVICE

The contractor guarantees that in the delivery are no execution or material defects and technical specification are in accordance with offer. The warranty period has a duration of 24 months from delivery. The service and maintenance warranty is 36 months. Any defects, complaints, etc., to be immediately known the contractor in writing by definite identification

The operating and maintenance instructions in the manuals are given to follow, to ensure that the warranty can be claimed. Excluded from the warranty is more natural wear and tear, improper handling and operation, inadequate or not performed in accordance with the maintenance requirements maintenance.

CHAP. 22) FIELD REPAIRS

For field repairs the employer will make the plant available at a mutually convenient time and will provide proper (reachable with a standard 40t-truck) access to the plant. The employer will also provide free of charge the use of cranes, hoists, station power and compressed air. All other items of equipment and materials required for the repairs shall be furnished by the contractor.

CHAP. 23) TEST RUN

The trial operation is spread over a period of 4 weeks after completion of commissioning with CC and handover of the plant to the employer. At the end of this period a FACC will be signed from both sides.

CHAP. 24) FORCE MAJEURE

If any Party should be prevented from fulfilling the whole contract or in parts for reasons of force majeure which may affect performance of his obligations he shall promptly notify the other party thereof. Such circumstance under force majeure means any circumstances beyond the control of the parties, including but not limited to:

- (a) war and other hostilities, (whether war be declared or not), invasion, act of foreign enemies, mobilisation, requisition or embargo;
- (b) ionising radiation or contamination by radio-activity from any nuclear fuel or from any nuclear waste from the combustion of nuclear fuel, radio-active toxic explosives, or other hazardous properties of any explosive nuclear assembly or nuclear components thereof;
- (c) rebellion, revolution, insurrection, military or usurped power and civil war;
- (d) riot, commotion or disorder, except where solely restricted to employees of the Contractor.

Art. 24.1) Effect of Force Majeure

Neither party shall be considered to be in default or in breach of his obligations under the Contract to the extent that performance of such obligation is prevented by any circumstances of Force Majeure which arise after the date of the confirmation order or the date when the Contract becomes effective, whichever is the earlier.

Art. 24.2) Performance to Continue

Upon the occurrence of any circumstances of Force Majeure the Contractor shall endeavour to continue to perform his obligations under the Contract so far as reasonable practicable. The Contractor shall notify the Employer of the steps he proposes to take including any reasonable alternative means for performance which is not prevented by Force Majeure. The Contractor shall not take any such steps unless directed so to do by the Employer.

Art. 24.3) Additional Costs caused by Force Majeure

If the Contractor incurs additional costs in complying with the Employer's directions under the above mentioned Clause "Performance to continue", the amount thereof shall be certified by the Employer and added to the Contract Price. When calculating the adjustment no account shall be taken of any increased cost which results from the Contractor's default or negligence.

Art. 24.4) Continuity of Payment

In case of force majeure in the sphere of the Employer the terms of payment are still to fulfil as agreed in this contract. The Employer cannot quit payment reference to force majeure.

In case of force majeure in the sphere of the Contractor the terms of payment are still to fulfil as agreed in this contract as far as the Contractor presents the necessary documents for the payment agreed in the terms of payment.

CHAP. 25) SPECIAL TERMS AND CONDITIONS

All instructions, approvals and notices to Contractor shall be issued or confirmed by the Employer in writing. Basically the communication is in English. Some detailed descriptions may be written in German.

The Employer reserves the right to visit the Contractor's factory and witness any examinations as far as it is possible in the workshop. The Contractor shall give due notice, approx. 7 days before the execution of any examination. During the inspection and/or the examination the Employer reserves the right to demand the immediate replacement of the faulty materials or the improvement of the goods according to the specification, in case the goods are not in accordance with the specifications stipulated herein. All cancellation or replacement expenses will be shouldered by the Contractor. The Contractor is liable to give any reasonable assistance, required by the Employer.

Should the Employer decide to cancel the project, all the costs and the expenses due to the cancellation shall be paid to the Contractor. The Contractor shall immediately stop the production upon receipt of the cancellation.

If the Employer decides to suspend the works or any part thereof for a certain period, the Contractor shall, on the written order of the Employer, suspend the progress of the works or any part thereof for such period, or periods, and in such manner which he considers necessary and shall, during such suspension, properly protect and secure the work so far as it is necessary. The extra costs born to the Contractor, by handling according to the Employer's instructions shall be shouldered and paid by the Employer.

Provided that the Contractor is entitled to recover any such extra cost, he shall give written notice of his intention to claim to the Employer, within fourteen days of the Employer's order. The Employer shall consider such an extra payment and/or extension of time to be made to the Contractor in respect of such claim and shall be fair and reasonable.

CHAP. 26) PLACE OF JURISDICTION

The place of jurisdiction is exclusively the international arbitration tribunal of vienna commodity market, AUSTRIA.

CHAP. 27) ARBITRATION

All disputes arising out of or in connection with the present contract shall be finally settled under the Rules of Arbitration of the International Chamber of Commerce by one or more arbitrators appointed in accordance with the said Rules.

CHAP. 28) LITIGATION

In the case where any litigation may arise, the Employer or the Contractor must clearly and explicitly explain the reason for litigation by registered mail. The other party must then formulate their answer with adapted solutions, no later than 15 days after receipt of litigation. Any dispute arising from the execution of an agreement shall be settled by discussion and agreement between the two parties.



wasserkraft
GmbH & Co KG

TECHNOLOGY FOR HYDRO-ELECTRIC POWER
complete engineering solutions for hydro-electric power plants and revitalization
www.wws-wasserkraft.at

A-4120 Neufelden, Oberfeuchtenbach 11

agreements between the two parties.

CHAP. 29) LEGAL VENUE

If however the parties fail to agree all disputes arising out of or in connection with the present contract shall be finally settled under the Rules of Arbitration of the International Chamber of Commerce by one or more arbitrators appointed in accordance with said Rules and under the application of the Swiss laws. The provisions of the United Nations Convention on contracts for the international sale of goods ("The Vienna Convention") are hereby excluded from the contract. The legal venue of the arbitration will be at the Chamber of Commerce in Zurich, Switzerland. English language shall be applied for arbitration.

CHAP. 30) LIMITATION OF LIABILITY

The overall liability of the contractor is limited to the amount equivalent to 5% of the total contract..

The part with the biggest sound level is generator. WWS Wasserkraft take no liability for any amerce or indemnity as a consequence of noise.

CHAP. 31) LIMITATION FOR INDIRECT OR CONSEQUENTIAL DAMAGE

Neither party shall be liable to the other for any loss of profit, loss of use, loss of production, loss of contracts or for any other indirect or consequential damage that may be suffered by the other, except of wilful causation.

CHAP. 32) COMING INTO FORCE

The contract shall come into force after signature, receipt of down payment and opening and confirmation of L/C.

CHAP. 33) ASSISTANCE TO THE EMPLOYER

The Contractor has to provide the following services free of charge:

Training of the staff which will be operating and maintaining the plant. Training will be in English.

The Employer will have a representative on site during assembly and installation.

CHAP. 34) PRICES

Prices are expressed in EURO and are binding only after confirmation by the contractor

CHAP. 35) RETENTION OF TITLE

The delivered merchandise remain until complete payment property of the company WWS GmbH & CoKG. It is the extended retention of title.

CHAP. 36) VALIDITY OF THE OFFER

This offer is valid until 25.01.2017

CHAP. 37) DOCUMENT PRIORITY

If the documents in the contract contain mutually conflicting terms, the following documents shall apply in the following order:

- a) the contract document (Confirmation of Order, Purchase Agreement, ect.),
- b) General Conditions of Sale and Delivery of WWS Wasserkraft GmbH & Co KG, A-4120 Nefelden
- c) the tender/offer,
- d) given technical specifications
- e) acknowledged drawings
- f) The General Terms of Delivery of the Association of Austrian Machinery and Steel Construction Industries" and "The General Terms of Delivery of the Austrian Electrical and Electronics Industry"
- g) the invitation to tender with underlying documentation/the inquiry with underlying documentation

For issues not covered in the contract document, the "General Conditions of Sale and Delivery of the company WWS Wasserkraft GmbH & Co KG, A-4120 Neufelden" come in force.

If no contract document is to be drawn up, the Employer's written order shall in relation to the first paragraph be regarded as such a contract document, after the order has been accepted in writing by the Contractor.

Due to our longstanding experience in the design, construction and erection of equipment for hydro power plants we, WWS Wasserkraft we will assure you the best fulfillment of the contract and that you will be satisfied with our product and services.

Sincerely with best regards

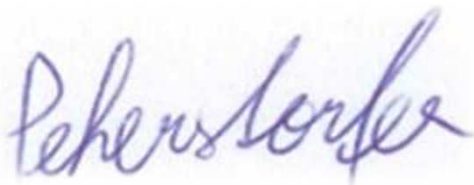

Mr. Markus PEHERSTORFER
Sales Manager

WWS WASSERKRAFT GmbH & Co KG

Project: Untergeng - Austria

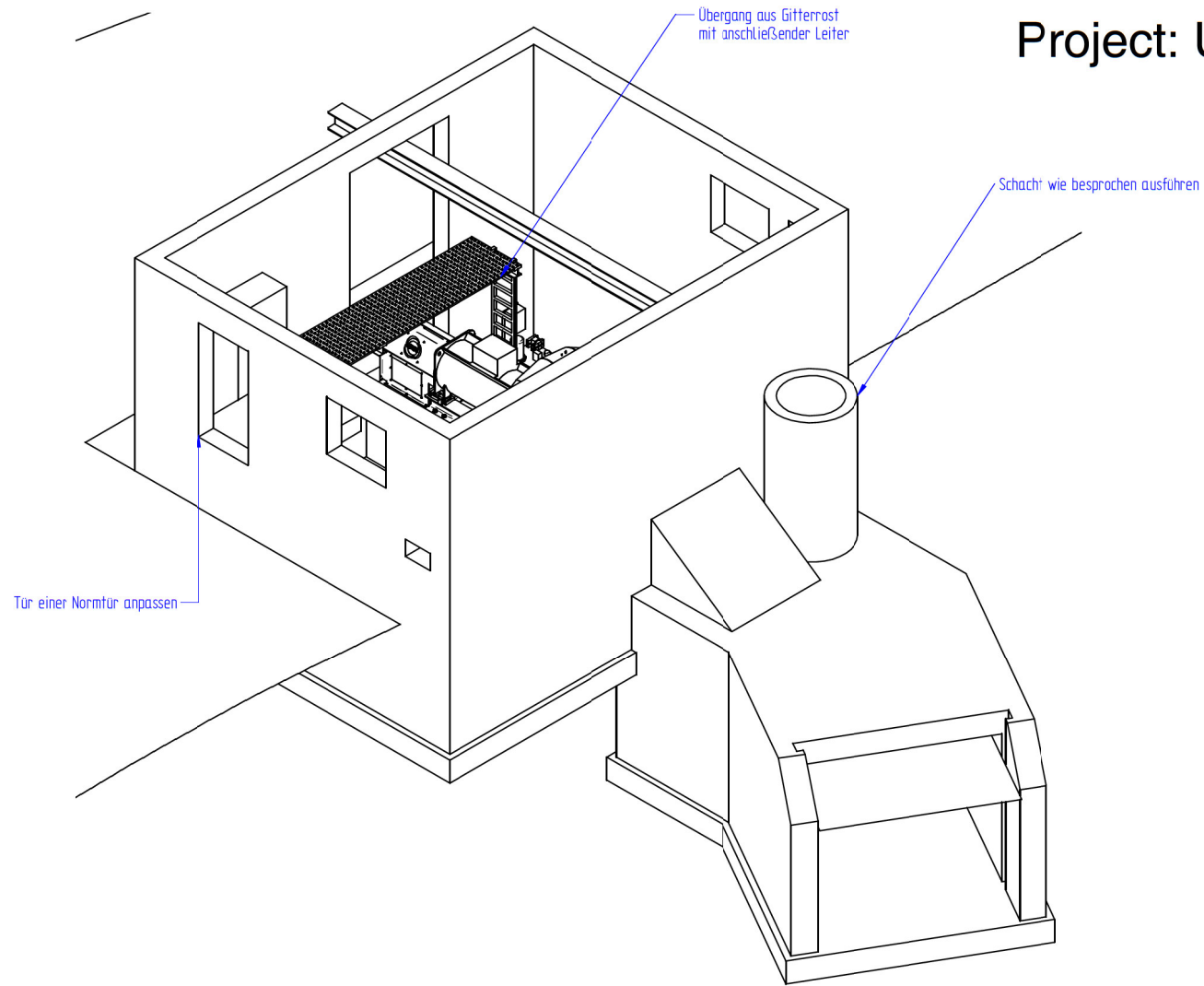

Aussparung wird mit U-Träger ausgeführt werden von Firma WWS-Wasserkraft beigestellt

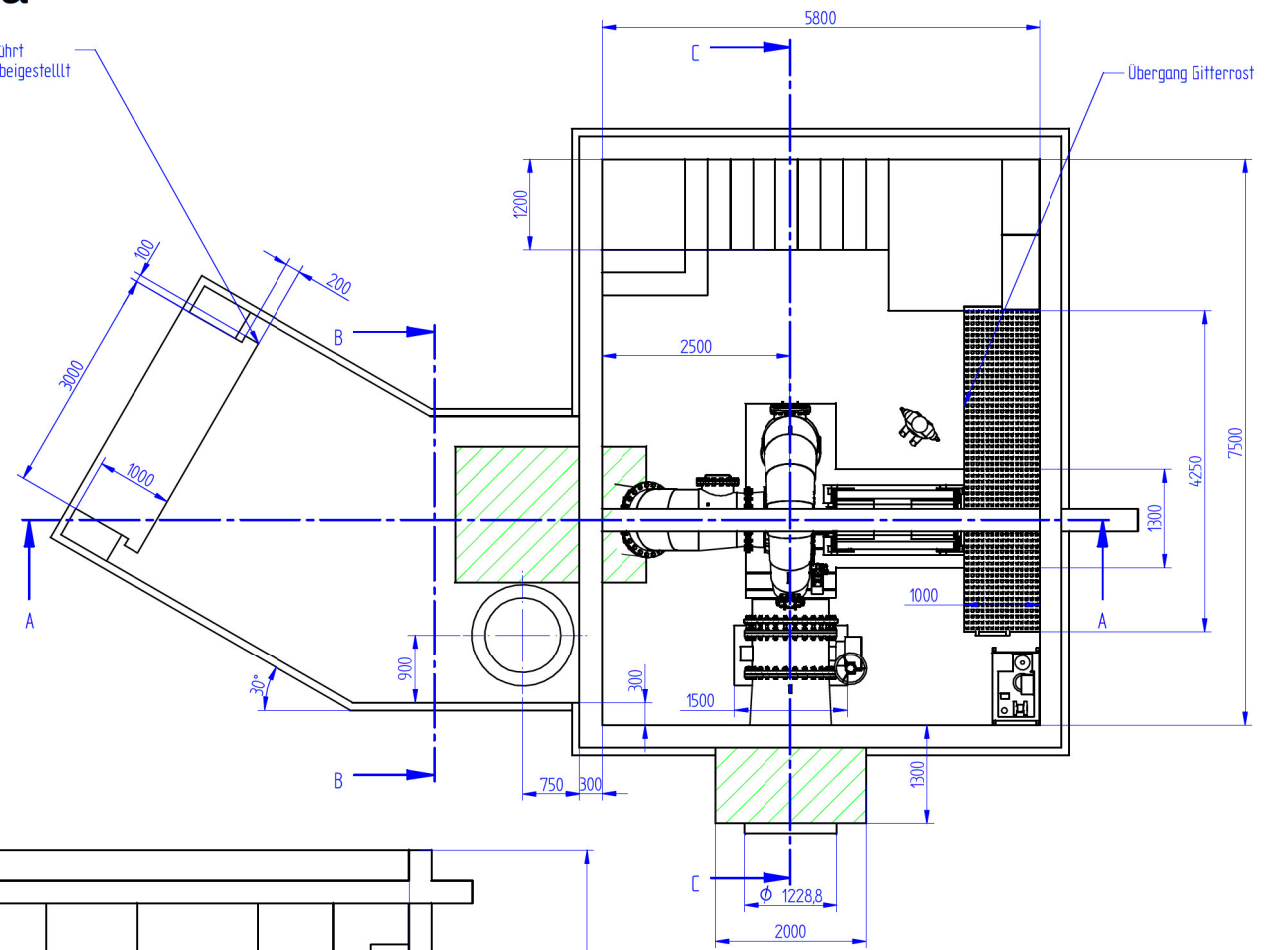

2. Betonabschnitt erst nach Montage

Gewichtsangaben (Kran)
Turbine ohne Generator = 4t
Generator = 3t

Project dates:
net head: 6,35m
flow rate: 2,30m³/s

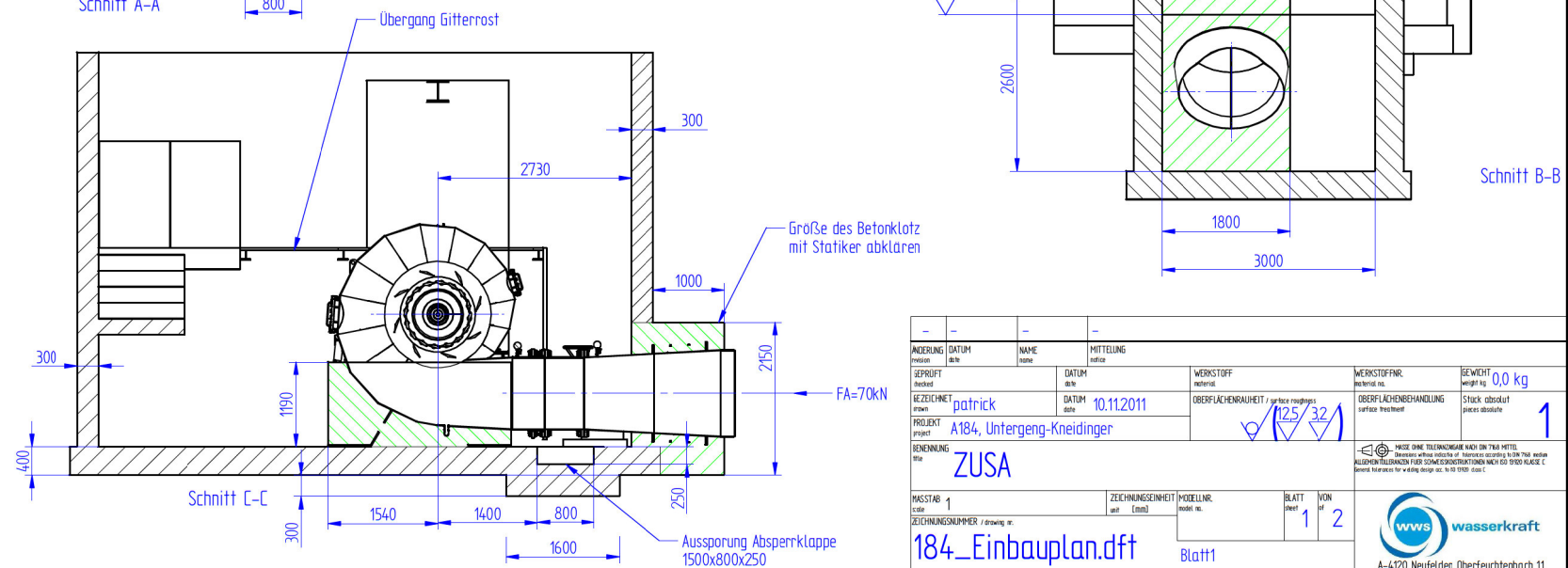
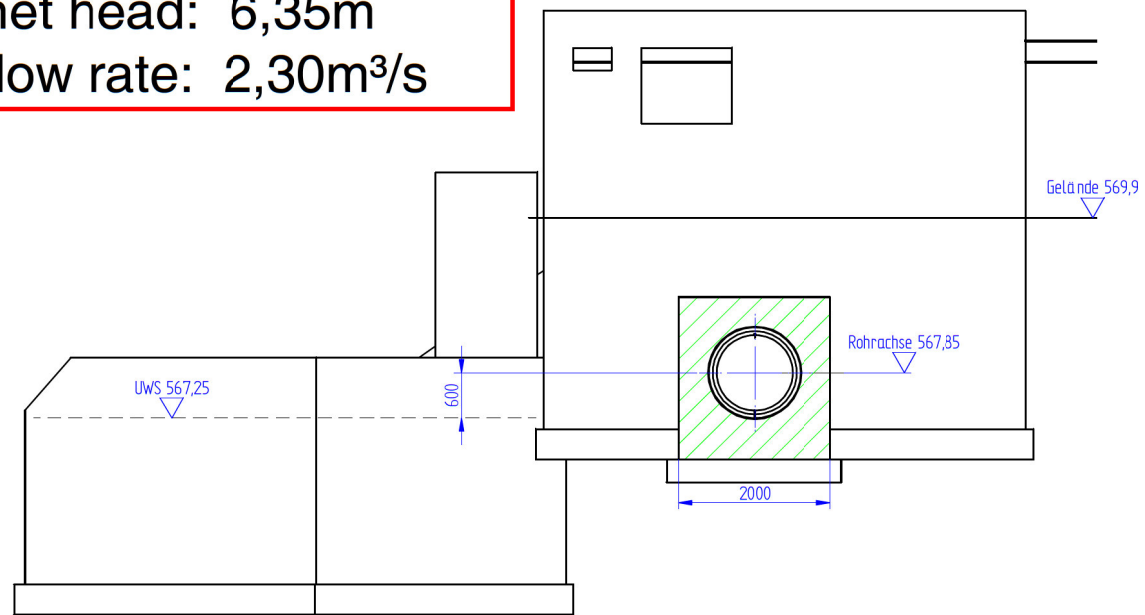
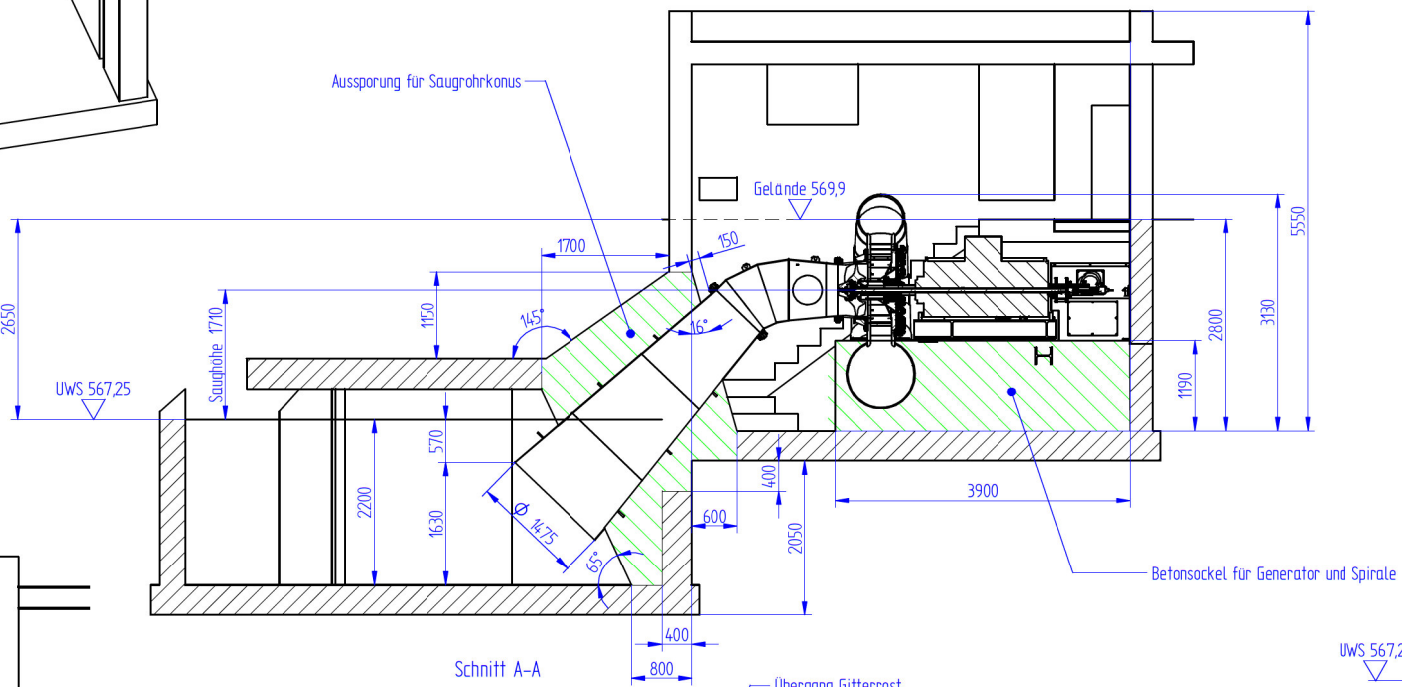

ÄNDERUNG	DATUM	NAME	MITTEILUNG	WEKSTOFF	WEKSTOFFNR.	GEWICHT
nr.	date	name	infos	material	material no.	weight kg
GEPRÜFT						0,0
ZEICHNET	DATUM			OBERFLÄCHENRAUHEIT	OBERFLÄCHENBEHANDLUNG	Stück absolut
patrick	10.11.2011			$\sqrt{12,5/32}$	surface treatment	1
PROJEKT: A184, Untergeng-Kneidinger ZUSAMMENGESETZT VON: ZUSA MASSTAB: 1 ZEICHNUNGSNOMMER: 184_Einbauplan.dft BLATT 1 VON 2 Blatt 1 wws wasserkraft A-4120 Neufelder, Oberfeuchtenbach 11 +43 7282 5922 www.wasserkraft.at						

Die Arbeit dieser Zeichnung ist unser geistiges Eigentum der Firma www.wasserkraft.at. Die Zeichnung ist dem Empfänger nur zum persönlichen Gebrauch überlassen. Eine weitere schriftliche Bewilligung darf nie wieder erteilt werden. Nach dem Gebrauch ist die Zeichnung an den Auftraggeber zurückzugeben.



MIHOESTI 1

RUMÄNIEN | ROMANIA

LIEFERUMFANG Turbine, Hydraulik,
Generator

ANZAHL MASCHINEN 1

TURBINENTYP Kaplan Spiralturbine

FALLHÖHE 17,5 m

NENNDURCHFLUSS 8,0 m³/s

NENNLEISTUNG 1.236 kW

LAUFRADDURCHMESSER 1.200 mm

EQUIPMENT Turbine, Hydraulic,
Generator

NR. OF TURBINE 1

TYP Kaplan spiral turbine

NET HEAD 17,5 m

FLOW RATE 8,0 m³/s

POWER 1.236 kW

RUNNER DIAMETER 1.200 mm



UNTERGENG

ÖSTERREICH | AUSTRIA

LIEFERUMFANG	Turbine, Hydraulik, Generator, Stahlwasserbau, Steuerung, Schaltanlage
ANZAHL MASCHINEN	1
TURBINENTYP	Kaplan Spiralturbine
FALLHÖHE	6,35 m
NENNDURCHFLUSS	2,30 m ³ /s
NENNLEISTUNG	130 kW
LAUFRADDURCHMESSER	700 mm

EQUIPMENT	Turbine, Hydraulic, Generator, Hydraulic steel construction, Control system, Switchgear
NR. OF TURBINE	1
TYP	Kaplan spiral turbine
NET HEAD	6,35 m
FLOW RATE	2,30 m ³ /s
POWER	130 kW
RUNNER DIAMETER	700 mm



FÜHRER

ÖSTERREICH | AUSTRIA

LIEFERUMFANG	Turbine, Hydraulik, Generator, Stahlwasserbau, Steuerung, Schaltanlage
ANZAHL MASCHINEN	1
TURBINENTYP	Kaplan Schachtturbine
FALLHÖHE	2,3 m
NENNDURCHFLUSS	6,0 m ³ /s
NENNLEISTUNG	120 kW
LAUFRADDURCHMESSER	1.500 mm

EQUIPMENT	Turbine, Hydraulic, Generator, Hydraulic steel construction, Control system, Switchgear
NR. OF TURBINE	1
TYP	Kaplan open flume turbine
NET HEAD	2,3 m
FLOW RATE	6,0 m ³ /s
POWER	120 kW
RUNNER DIAMETER	1.500 mm



THEUERWANGWEHR

ÖSTERREICH | AUSTRIA

LIEFERUMFANG	Turbine, Generator, Stahlwasserbau, Steuerung, Schaltanlage
ANZAHL MASCHINEN	1
TURBINENTYP	Kaplan Schachtturbine
FALLHÖHE	3 m
NENNDURCHFLUSS	15,0 m ³ /s
NENNLEISTUNG	408 kW
LAUFRADDURCHMESSER	2.000 mm

EQUIPMENT	Turbine, Generator, Hydraulic steel construction, Control system, Switchgear
NR. OF TURBINE	1
TYP	Kaplan open flume turbine
NET HEAD	3 m
FLOW RATE	15,0 m ³ /s
POWER	408 kW
RUNNER DIAMETER	2.000 mm

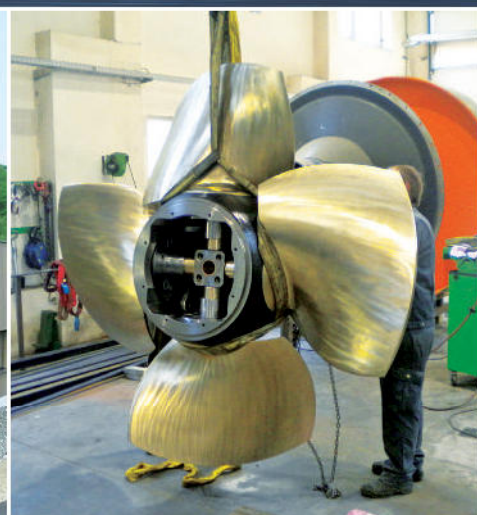

POLLINGER

ÖSTERREICH | AUSTRIA

LIEFERUMFANG	Turbine, Hydraulik, Generator, Stahlwasserbau, Steuerung, Schaltanlage	EQUIPMENT	Turbine, Hydraulic, Generator, Hydraulic steel construction, Control system, Switchboard
ANZAHL MASCHINEN	1	NR. OF TURBINE	1
TURBINENTYP	Kaplan Split Rohrturbine	TYP	Kaplan split bulb turbine
FALLHÖHE	6,0 m	NET HEAD	6,0 m
NENNDURCHFLUSS	6,0 m ³ /s	FLOW RATE	6,0 m ³ /s
NENNLEISTUNG	320 kW	POWER	320 kW
LAUFRADDURCHMESSER	1.100 mm	RUNNER DIAMETER	1.100 mm

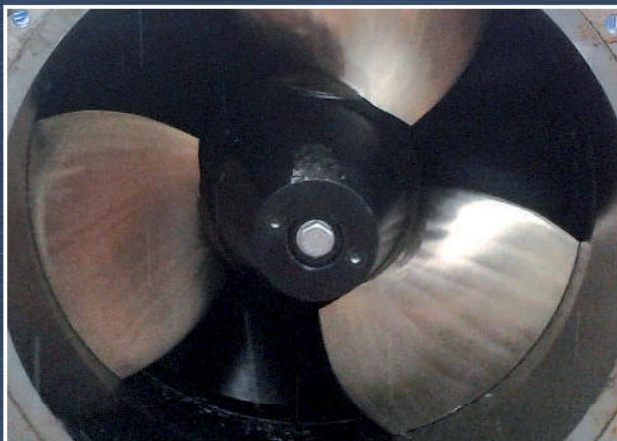

BERDU 2

RUMÄNIEN | ROMANIA

LIEFERUMFANG	Turbine, Hydraulik
ANZAHL MASCHINEN	1
TURBINENTYP	Kaplan Pit Turbine 3-flügelig
FALLHÖHE	9,45 m
NENNDURCHFLUSS	9,0 m ³ /s
NENNLEISTUNG	709 kW
LAUFRADDURCHMESSER	1.100 mm

EQUIPMENT	Turbine, Hydraulic
NR. OF TURBINE	1
TYP	Kaplan pit turbine 3-blades
NET HEAD	9,45 m
FLOW RATE	9,0 m ³ /s
POWER	709 kW
RUNNER DIAMETER	1.100 mm

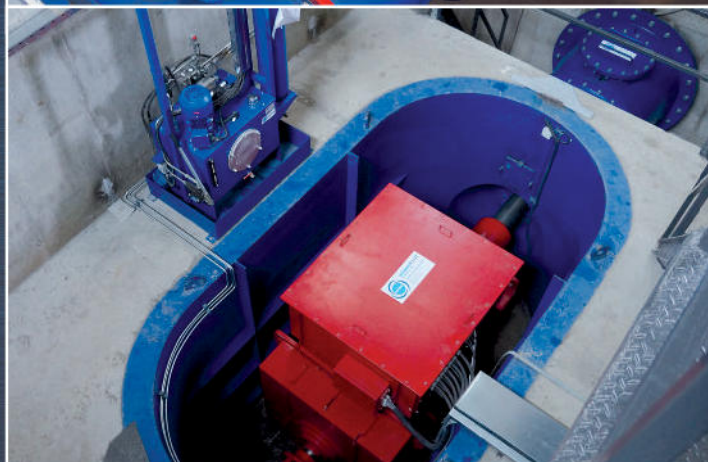

OBERPFINNINGSTEIGMÜHLE

ÖSTERREICH | AUSTRIA

LIEFERUMFANG	Turbine, Generator, Stahlwasserbau, Steuerung, Schaltanlage
ANZAHL MASCHINEN	1
TURBINENTYP	Kaplan Schachtturbine mit PM Generator
FALLHÖHE	1,85 m
NENNDURCHFLUSS	8,0 m ³ /s
NENNLEISTUNG	132 kW
LAUFRADDURCHMESSER	1.800 mm

EQUIPMENT	Turbine, Generator, Hydraulic steel construction, Control system, Switchgear
NR. OF TURBINE	1
TYP	Kaplan open flume turbine with PM-Generator
NET HEAD	1,85 m
FLOW RATE	8,0 m ³ /s
POWER	132 kW
RUNNER DIAMETER	1.800 mm

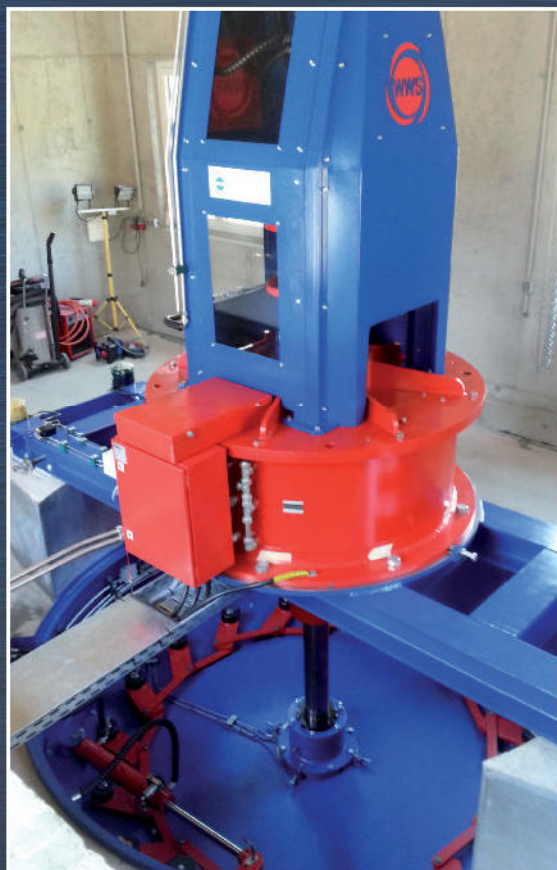

RIEDMÜHLE

ÖSTERREICH | AUSTRIA

LIEFERUMFANG	Turbine, Generator, Stahlwasserbau, Steuerung, Schaltanlage
ANZAHL MASCHINEN	1
TURBINENTYP	Kaplan Schachtturbine
FALLHÖHE	2,6 m
NENNDURCHFLUSS	2,8 m ³ /s
NENNLEISTUNG	64 kW
LAUFRADDURCHMESSER	950 mm

EQUIPMENT	Turbine, Generator, Hydraulic steel construction, Control system, Switchgear
NR. OF TURBINE	1
TYP	Kaplan open flume turbine
NET HEAD	2,6 m
FLOW RATE	2,8 m ³ /s
POWER	64 kW
RUNNER DIAMETER	950 mm



Client:

SCULLY CONSULTING SERVICES

North Bennington
Vermont, USA

Processor

Contact: Mr. Markus PEHERSTORFER

Phone: +43 7282 5922 44

Fax: +43 7282 5922 21

Email: m.peherstorfer@wvs-wasserkraft.at

Subject:

BUDGETARY OFFER

Date:

08.11.2016

Dear Mr. Scully

Thank you for your request from the 29.09.2016 regarding your small hydro power plant project.

We gladly offer you the following turbine(s):

Project: Firehouse Dam

WWS-KSA600-4-410-R



BANK ACCOUNT

Raiffeisenbank Reg. Rohrbach
IBAN: AT83 3441 0000 0600 1994
BIC: RZOOAT2L410

VAT Reg. No./ COMMERCIAL REGISTER

ATU64372869
FN312926k
EORI: ATEOS1000018633

COMPLEMENTARY

Wasserkraft GmbH
head office: 4120 Neufelden
LG Linz, FN310635t



SUMMARY

I	TECHNICAL DATA Turbine Design and Specifications	Page 3
II	PERFORMANCE & EFFICIENCY Efficiency & Output Graph Efficiency Table	Page 4
III	PRICE LIST Main Price List Optimal Equipment List Spare Part & Service Packages	Page 5
IV	SCOPE OF SUPPLY AND SERVICES	Page 7
A	Hydraulic Turbine 1 WWS-KSA600-4-410-R	Page 7
B	Turbine Accessories 1 Generator 2 & 4 Draft Tube cone & Belt Drive 5 Hydraulik Power Unit 7 & 8 Technical Documentation & Basic Consultation 9 Protection Covers & Railings	Page 10
C	Electrical Equipment 1 Turbine Control & Protection System 2 & 3 & 4 Low Voltage Switch Syst. & Main Power Transformer & Med. Voltage Switch Syst. 5 & 6 Battery Syst. & DC distribution 24V & SEAMTEC SCADA Basic System 7 & 8 Fault Message Service & Remote Operation 9 & 10 Power Cable Set and Cable Trays & Engineering & Documentation	Page 16
D	Erection & Training 1 & 2 Erection on site & Commissioning and Training 3 Travelling Costs	Page 26
E	Packaging & Transport 1 & 2 Seaworth Packaging & Transport	Page 27
F	Optional Equipment	Page 28
G	Spare parts	Page 36
H	M & S Package	Page 38
V	TURBINE MEASUREMENTS (preliminary)	Page 40
VI	TERMES OF PAYMENT	Page 41
VII	TIME OF DELIVERY	Page 41
VIII	CONTRACT CONDITIONS	Page 42

I) TECHNICAL DATAS	Projektname:	Firehouse Dam
---------------------------	--------------	----------------------

1	Stück					
Turbine Type:		WWS-KSA600-4-410-R				
Gross Head:		3,65	m			
Net Head:		3,5	m	Total Discharge Volume:		
Turbine Discharge:		1,36	m ³ /s	48,3	ft ³ /s	
		1,36	m ³ /s			
Turbine Speed:		410	rpm			
Runner Blades:		4	Total Turbine Power Output:			
Runner Diameter:		600	mm			
Turbine Power Output:		41	kW	41	kW	
Belt Transmission:		YES R				
Generator Speed:		1200	rpm	Total Electrical Power Output:		
Generator Voltage:		400	V			
Generator Power Output:		36	kW	36	kW	
Nominal Power Generator:		45	kW			
Grid Voltage		--	kV			
Frequency		60	Hz			
Suction Head:		+30,0	m			
Elevation Turbine Axis:		---	m a.s.l.			



II) PERFORMANCE & EFFICIENCY	per Unit at rated net head of:	3,5	m	
---	--------------------------------	------------	---	--

The Turbines are manufactured at WWS Wasserkraft GmbH & Co KG. Every hydraulic profile was developed with a numeric simulation performed by the renowned technical university of Graz, Austria and guarantess highest efficiency. The below mentioned values are stated with a margin for safety and higher efficiency can be expected in operation.

Q_T	Turbine discharge	net head	Efficiency Turbine	Turbine Output	Efficiency Generator	Efficiency Belt	Generator Output
%	m ³ /s	m	%	kW	%	%	kW
20	0,27	3,50	84,0%	7,8	84,0%	97,0%	6,4
30	0,41	3,50	86,3%	12,1	86,5%	97,0%	10,1
40	0,54	3,50	89,0%	16,6	89,0%	97,0%	14,4
50	0,68	3,50	90,0%	21,0	91,0%	97,0%	18,5
60	0,82	3,50	90,6%	25,4	92,1%	97,0%	22,7
70	0,95	3,50	90,8%	29,7	92,4%	97,0%	26,6
80	1,09	3,50	90,3%	33,7	92,4%	97,0%	30,2
90	1,22	3,50	89,4%	37,6	92,2%	97,0%	33,6
100	1,36	3,50	88,3%	41,2	91,1%	97,0%	36,4

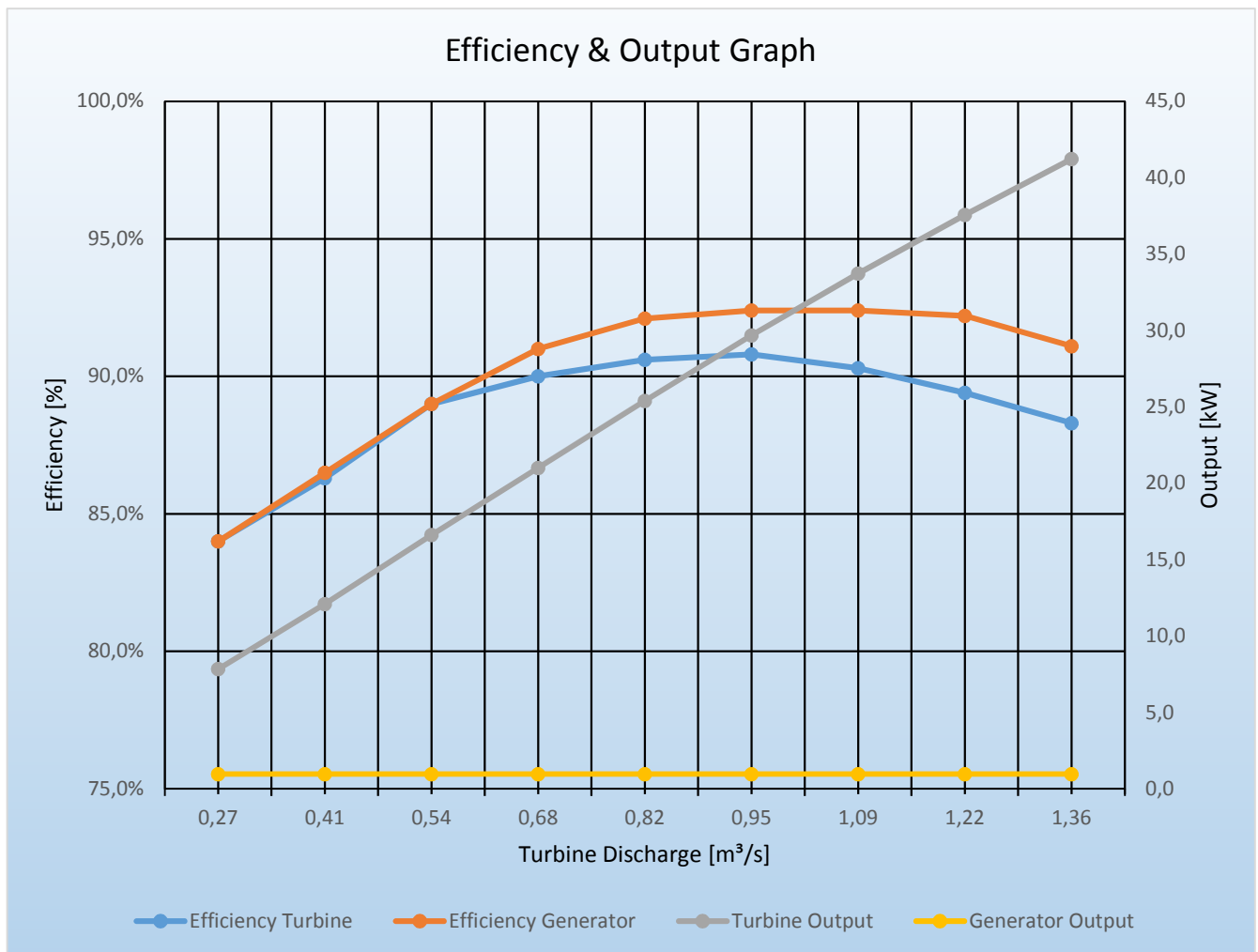



III) PRICE LIST	Project Name:	Firehouse Dam
------------------------	---------------	----------------------

Pos.	Part	Qty:	Unit Price:	Price	
1	WWS-KSA600-4-410-R	1	€ 78.500	€ 78.500	
A	TOTAL PRICE Hydraulic Turbine			€ 78.500	
1	Generator	1	€ 15.500	€ 25.300	
	400V 1200rpm 45kW 1000m Roller Bearing		Options: € 9.800		
2	Draft Tube cone	1	€ 2.500	€ 2.500	
3	Draft tube elbow	0	€ 8.600	Option	
4	Belt Drive	1	€ 9.500	€ 9.500	
5	Hydraulik Power Unit	1	€ 12.000	€ 12.000	
6	Automatic Grease Pumps	0	€ 2.050	Option	
7	Technical Documentation	1	€ 1.000	€ 1.000	
8	Basic Consultation	1	€ 5.800	free of charge	
9	Protection Covers & Railings	0	€ 4.500	Option	
B	TOTAL PRICE Turbine Accessories			€ 50.300	
1	Turbine Control & Protection System	1	€ 20.400	€ 20.400	
2	Low Voltage Switch Syst.	1	€ 17.600	€ 17.600	
3	Main Power Transformer	0	€ 0	Option	
3a	Aux. Unit Transformer	0	€ 0	Option	
4	Med. Voltage Switch Syst.	0	€ 0	Option	
5	Battery Syst. & DC distribution 24V	1	€ 2.200	€ 2.200	
6	SEAMTEC SCADA Basic System	0	€ 7.300	Option	
7	Fault Message Service	0	€ 2.500	Option	
8	Remote Operation	0	€ 2.200	Option	
9	Power Cable Set and Cable Trays	1	€ 2.500	€ 2.500	
10	Engineering & Documentation	1	€ 2.800	€ 2.800	
C	TOTAL PRICE Electrical Equipment			€ 45.500	
1	Erection on site	1	€ 15.500	€ 15.500	
2	Commissioning and Training	1	€ 1.700	€ 1.700	
3	Travelling Costs	1	€ 7.500	€ 7.500	
D	TOTAL PRICE Erection & Training			€ 24.700	
1	Seaworth Packaging	1	€ 1.500	€ 1.500	
2	Transport	1	€ 3.500	€ 3.500	
E	TOTAL PRICE Packaging & Transport			€ 5.000	
F	TOTAL PRICE Optional Equipment			€ 0	
G	TOTAL PRICE Spare parts			€ 0	
H	TOTAL PRICE M & S Package			€ 0	
	TOTAL PRICE			€ 204.000	

Please see next page for prices of optinal equipment and other services!

Optional Equipment List

Upon request to optimized your power plant!

Pos.	Part				Qty:	Unit Price:	Price
1	Runner Blades made of 1.4313				0	€ 2.400	Option
2	Biodegradeable Oil for runner hub				0	€ 80	Option
3	2nd Pump unit for HPU	DC	230V	0	€ 1.700	Option	
4	Humidity Absorbing Filter for HPU				0	€ 400	Option
5	Proportional Valves for HPU				0	€ 2.200	Option
6	Biodegradeable Oil for HPU	Panolin	M = 100L	0	€ 750	Option	
7	Wicket Gate Monitoring	Qty.	18	0	€ 5.400	Option	
8	Bridge Crane incl. Rails	100 kN	L=10m	0	on request	Option	
9	SEAMTEC SCADA Enterprise System				0	€ 17.800	Option
10	Condition Monitoring	4 Sensor(s)		0	€ 6.270	Option	
11	Redundant CPU Solution				0	€ 8.000	Option
12	Monitoring Camera - Outdoor				0	€ 2.500	Option
13	Camera Surveillance System	3 Cams		0	€ 12.310	Option	
14	Weather Station				0	€ 5.500	Option
15	Additional Water Level Sensor				0	€ 1.250	Option
16	Smoke Detector - Power House				0	€ 500	Option
17	Electrical Installation - Power House				0	€ 9.800	Option
18	Ventilation System - Power House	3800m³/h		0	€ 640	Option	
19	Temperatur Sensor - Power house	PT100		0	€ 380	Option	
20	Generator Neutral Cubicle				0	€ 7.900	Option
21	Transformer Neutral Cubicle				0	€ 8.200	Option
22	Diesel Generator	400V	60 Hz	60 kVA	0	€ 17.000	Option
23	Detailed QA/QC Protocol				0	on request	Option
F	TOTAL PRICE Optional Equipment					€ 0	

Spare Parts

Containing wear parts, sealings, valves, sensors, limit switches ect.

Pos.	Part				Qty:	Unit Price:	Price
1	Spare Parts Turbine / Main Valve				0	on request	Option
2	Spare Parts Generator				0	on request	Option
3	Spare Parts (Governor, Hydraulic power unit)				0	on request	Option
4	Spare Parts Electrical Equipment				0	on request	Option
G	TOTAL PRICE Spare parts					€ 0	

Maintenance & Service Packages (per anno)

For detailed description check point II) H in the technical description below

Pos.	Part				Qty:	Unit Price:	Price
1	Maintenance Contract				0	on request	Option
2	Service Package Standard				0	on request	Option
3	Service Package Premium				0	on request	Option
4	Service Package All Inclusive				0	on request	Option
H	TOTAL PRICE M & S Package					€ 0	

IV) SCOPE OF SUPPLY AND SERVICES

A Hydraulic Turbine

Preface

Including Kaplan open flume turbine with vertical shaft. Runner mounted onto the turbine shaft. Hydraulically double regulated turbine set with adjustable runner blades as well as regulated guide vanes at the wicket gate to maximize efficiency over the entire load range. The transmission from the Kaplan runner to the generator happens via two calculated belt pulleys and an endless belt to achieve exact runner and generator rotation speed. All parts are calculated, designed and manufactured by WWS Wasserkraft and made accurately to European EN Standards. All materials used by WWS Wasserkraft are new, of high quality and internationally standardized. WWS turbines are designed to run on low maintenance and developed for long life time.

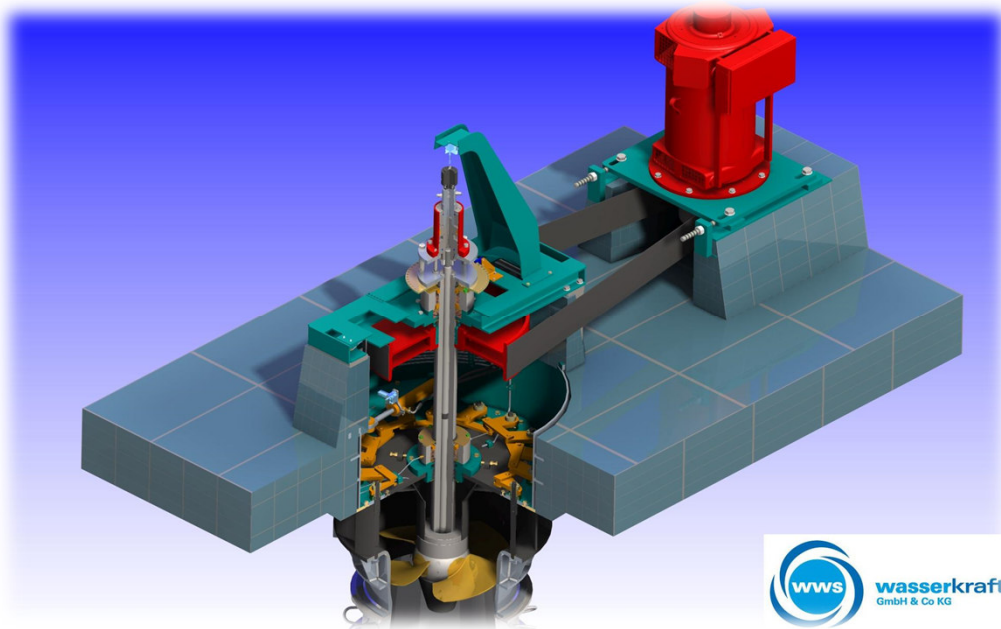

Turbine Housing:

The turbine housing and open flume design is a welded structure made of steel S355J2+N (1.0570) according to DIN EN10025-2. The complete inside of the housing is coated with Zinga® before it gets primed and painted with RAL industrial paint. Outer areas are untreated.

The turbine housing mainly consists of the outer duct with anchors for embedding in concrete and stiffening ribs for support, the wall ring to hold the upper wicket gate ring, supporting for the lower wicket gate ring, the bed plate to contain the main bearing, turbine top cover with guide cone and shaft protection tube, end shield to hold the guide bearing as well as a condensate drain pipe. All connections flanges are mechanically processed.

Turbine Shaft

Made out of C45E (1.1191), designed as a hollow shaft and mechanically processed. Designed to withstand the radial force caused by the belt transmission.

Turbine Shaft Bearings

The main bearing unit, consisting of an axial and a radial spherical roller bearing is designed for grease lubrication, with easy accessible grease points, seals and temperature control devices. The guide bearing is a roller bearing also designed for grease lubrication. The bearing housing also consists of a drain hole for leak water. Turbines with a runner diameter larger than 2m and a lower located bearing additionally consist of a drain pump and a floating switch which will be activated before water contacts bearings.

Turbine Shaft Sealing:

Consisting of specialized and corrosion-free labyrinth sealing as well as two additional rotary shaft seals. The sealings are prepared for grease lubrication with bio-degradable grease and run on hardened and stainless steel protection bushings.

Kaplan Runner Blades:

Kaplan runner blades made of Aluminum-Nickel-Bronze casting (G-CuAl10Ni). Designed according to a proven geometry calculated and simulated by the Technical University of Graz. Fitted onto the runner hub with a perfect fit, sealing rings as well as counter-mounted track disk which allows the blades to still being able to rotate.

On request the Kaplan runner blades can be also made out of stainless steel X3CrNiMo13-4 (1.4313) to achieve highest wear resistance and life time.

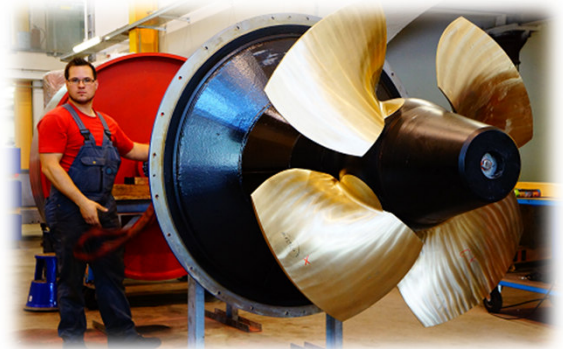

Runner Hub:

Made of spheroidal cast iron EN-GJS-500-7.
Sealed with maintenance free sealings. Housing is oil filled, also including runner blade adjustment mechanism. Fixed onto the turbine shaft by means of a oil press-fit.



Adjusting Rod:

Made of C45E (1.1191)
Connected from the runner blade adjustment mechanism, guided through the hollow turbine shaft to the outside of turbine / generator and connected to the double acting hydraulic cylinder to adjust the blade position angle.

Runner Blade Adjustment:

Runner blade position angle is adjusted via a double acting hydraulic cylinder using a transducer for position control and a perforated disc with speed recognition. The end position of the actuators are mechanically limited. The front side of the cylinder is directly mounted onto the turbine shaft.

Protection Bushing:

Bushings are made of hard-chrome plated stainless steel (1.4301) and fixed onto the extended generator shaft with three grub screws. Two O-rings seal the gap between shaft and bushing.
The bushings protect the generator shaft from tear wear so the shaft sealing can run on the protection bushings without damaging the generator shaft itself. In case of high abrasion the bushings can be exchanged easily and cost-efficient.

Wicket Gate Mechanism:

The water flow through the turbine is controlled via an adjustable wicket gate mechanism which acts as flow control unit and as primary closing device at the same time. The opening and closing of the wicket gate happens via a double acting hydraulic cylinder.

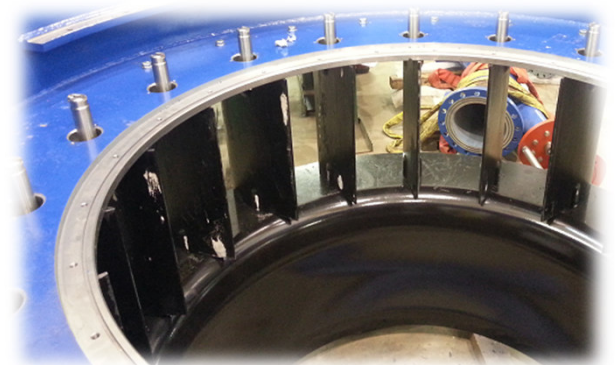

Wicket Gate Ring:

Separated wicket gate ring for easier maintenance. Made of steel S355J2+N (1.0570). Mounted between wall ring and turbine top cover.

Discharge Ring:

Made of steel S355J2+N (1.0570). The inside of the ring is turned onesided spherical to minimize gab between runner blades and discharge ring and to increase performance but it is still possible to remove turbine via top side without disassembling discharge ring. Discharge ring with stiffening ribs and anchors for embedding securely in the concrete foundation. Additionally serves as bottom wicket gate ring with bearing bushings for guide vane pins.



Guide Vanes:

The guide vanes designed as hydro-dynamic flow pattern are made of grey cast iron EN-GJS-600-3 (0.7060). Each guide vane has a stainless steel pin on the top and bottom side which are received in maintenance free and self-lubricated guide vane bearing bushings for smooth movement. The upper pin is connected to the wicket gate chain link system.

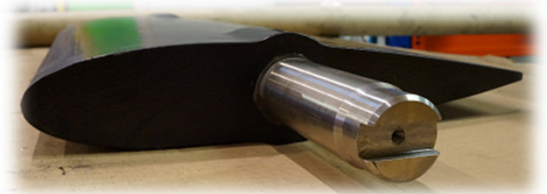

Guide Vane Bearing Bushings:

Exchangeable oil-free bushes. Top and bottom-side bearing bushings are made of sintered bronze. The top side bearing flanges which contain the bushing uses sealing rings to prevent leakage and is fixed on the upper wicket gate ring with screws.

Wicket Gate Chain Link:

To operate and move the guide vanes simulanenously via a chain link and link pin system. Every link connected to the guide vane is fixed with a torque limited clamping unit which will allow to slip over in case a guide vane cannot move due to some debris stuck between guide vanes (machine breakage prevention). As a result the wicket gate operating ring can still be operated without causing damage. The guide vane has a optical indicator and can easily be readjusted in case of shift.

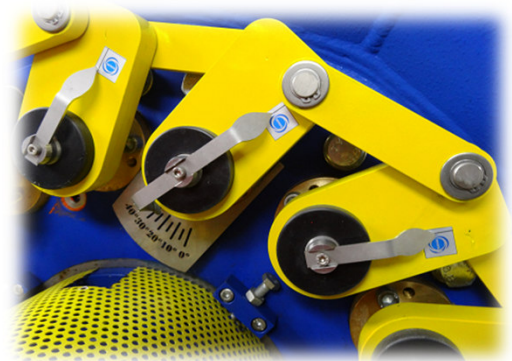

Wicket Gate Regulation:

The wicket gate will be automatically and regulated with a double-acting hydraulic cylinder mounted on the turbine housing. The piston rod is connected to a lever attached to the wicket gate operating ring. The position of the guide vanes can be supervised due to a linear potentiometer sending a feedback to the turbine control system and an additonal optical indicator directly on the hydraulic cylinder.

Corrosion Protection:

All connection elements which are in contact with water are made of stainless material.

As far as parts are not made of corrosion-resistant material the parts will undergo the following treatment to prevent corrosion:

Welded steel structures (turbine housing, draft tube, etc):

fully hot dip galvanized otherwise protected with Avenarius - Agrozinc SW

Surfaces in contact with water:

Sandblasted SA 2 ½,

2 priming coats with Agrozinc SW, 50µm each

2 top coats with Avertol Epotar, 200µm each

Hot-dip galvanised surfaces in contact with air:

1 top coat with Agropur Color ST, 100µm

Other surfaces in contact with air:

Sandblasted SA 2 ½,

2 priming coats with Agrozinc SW, 50µm each

1 top coat with Agropur Color ST, 100µm

Concreted areas:

No treatment

Description:

Agrozinc SW is a epoxy resin paint with zinc dust made by Avenarius Agro GmbH Germany

Avertol Epotar is a tar-oil epoxy compound made by Avenarius Agro GmbH Germany

Agropur Color ST is a 2-component-Polyurethane top coat made by Avenarius Agro GmbH Germany and is available in all RAL colour standards. WWS Wasserkraft uses RAL3000 (red) or RAL5010 (blue). Other colours can be used on request.

B Turbine Accessories

1 Generator

Three phase generator with asynchronous alternator with built-in self exciter machine and control system.
The grid code, electrical connection conditions and standards of the grid operator need to be published.

Brand	West-European	
Nominal output	[kW]	45
Ambient teperature	[° C]	40
Altitude max.	[m]	1000m
Power factor	-	0,9
Nominal voltage	[V]	400
Connection	-	star
Voltage regulation accuracy	[%]	+/- 1,5
Voltage adjusting range	[%]	+/- 10
Speed	[min ⁻¹]	1200
Overspeed	[min ⁻¹]	3000
Frequency	[Hz]	60
Isolation class	-	F
Temperature rise	-	B
Protection class	-	IP 21
Cooling system	-	IC 01
Sound level	[dB]	>90
Design	-	V1
Bearing	-	Roller Bearing
Minimal Bearing Life Time	[h]	>100.000 h
Radio interference suppression	-	N
Specification standard	-	VDE 0530, IEC 34
Painting	-	RAL 3000 or optional
Shaft rotation	-	optional
Voltage rotation	-	right
Cable outlet	-	down
Max. stops per day	-	3 stops/day

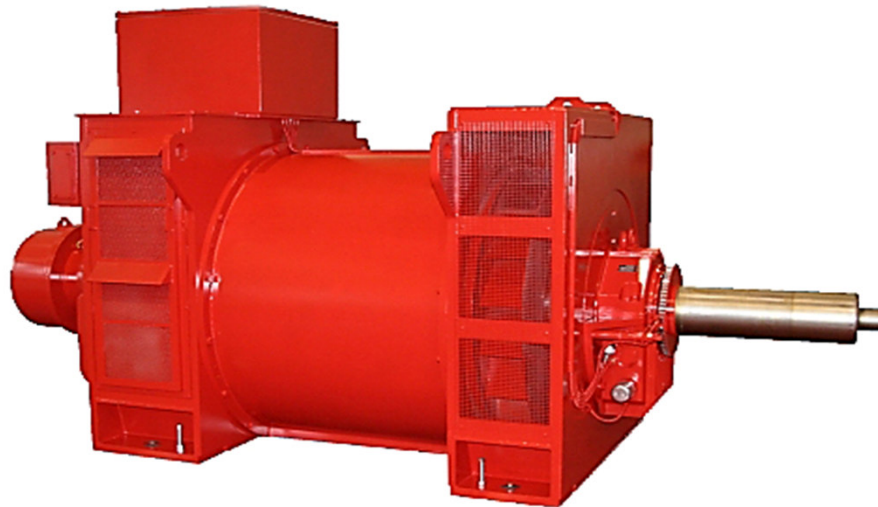

Efficiency:

Work Load	Efficiency in % at cos phi	
	0,9	1,0
100% load	90,6%	91,1%
75% load	91,8%	92,4%
50% load	90,5%	91,0%
25% load	84,4%	85,3%

Generator Accessories:

- Voltage regulator BASLER DECS100 or similar, installed
- Set value potentiometer for voltage adjustment, loose
- Temperature sensor PT 100 in stator winding, 1 pcs.per phase
- Winding head support wedges for excessive speed centrifugal
- Blanking plate with cable outlet
- Bearing temperature supervision PT100, 1 pcs. per bearing
- Reinforced bearings AS for receiving the turbine axial and centrifugal forces
- Foundation frame

Documentation:

- Operating and Maintenance Manual
- Power Connection Circuit Diagram
- Wiring Diagram
- Dimensional Drawing

The generator is the part with the highest noise level. The reason for this sound level is the cooling fan. This noise level can be reduced with a water cooled generator.

Optional Design & Technical Features for Turbine Generator

Pos.	Part			Qty:	Unit Price:	Price
1	Idle State Heating	230V	1000W	0	€ 500	Option
2	Compensation system			1	€ 9.800	€ 9.800
3	Sleeve Bearing + Lubrication System			0	€ 1.400	Option
4	External Lubrication System			0	€ 400	Option
5	Voltage & Current Transformer			0	€ 0	Option
6	BASLER DECS 250 instead BASLER DECS 100			0	€ 800	Option
7	Vibration Control			0	€ 400	Option
8	Short Circuit Ratio > 0,75	Value:	0,8	0	€ 300	Option
to B 1	TOTAL PRICE	Generator Options				€ 9.800

2 Draft Tube cone

Diameter Turbine Side: **DN 600**

designed as a welded structure made of S355J2+N (1.0570) containing draft tube cone. Draft tube cone is customized according to technical specifications, site conditions and hydro-dynamic requirements. Draft tube cone is connected to turbine housing via a flange and will be welded later on the lower part of the turbine. With anchors for embedding in concrete foundation and rigid stiffening ribs if necessary to assure maximum stability and compressive strength. Draft tube fully hot-dip galvanized if possible otherwise corrosion protection with Zinga[®]. Draft tube areas embedded in concrete will have no surface treatment for better bonding.

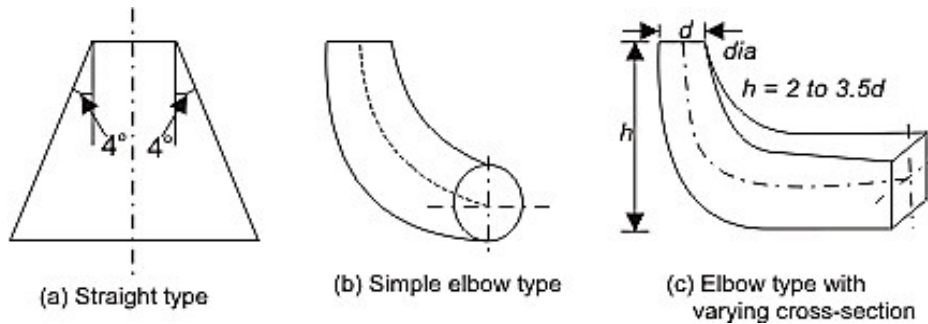

Samples of different draft tube designs according to different turbine layout or specifications:

3 Draft tube elbow

designed as a metal permanent formwork (delivered in one pc. or more), which guide the water from a vertical direction and a round surface with minimum of loss to a horizontal flow and rectangle surface. After this part a normal standard straight formwork can be used by the local construction company to finish the draft tube according instructions of WWS Wasserkraft. The draft tube formwork consists out of a very flat and grinded surface and have some stiffening ribs outside. Inside the surface is protected against corrosion with Zinga[®], outside it is for a better connection to the concrete not protected.

metal_elbow

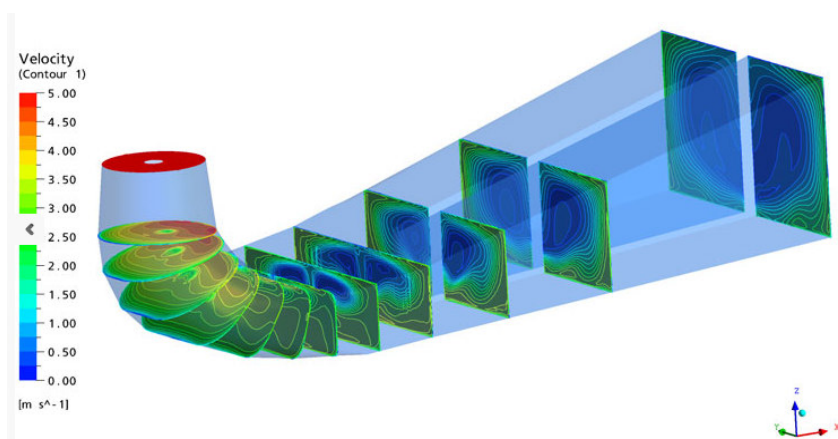
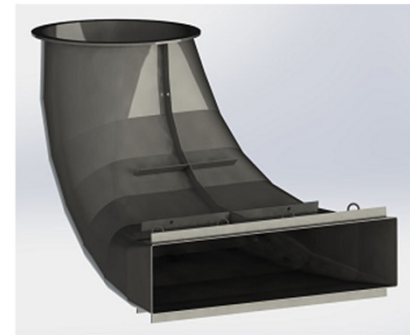

4 Belt Drive

Belt Transmission Unit: **YES**
Transmission Rate: **i=2,93**



Mainly consisting of flat belt, larger turbine pulley and small generator pulley. Flat belt pulleys are mounted on to the generator and turbine shaft via a clamping unit. The flat belt pulleys are made of S355J2+N according to DIN EN 10025-2. Made of a single piece. Running surface machined on turning machine to achieve a smooth surface. Finally painted with RAL epoxy paint and statically balanced.

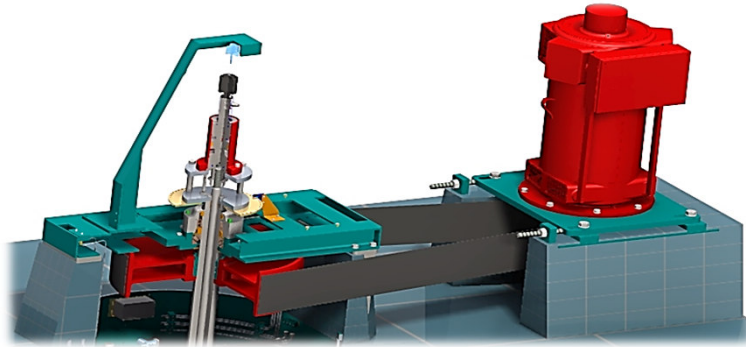

5 Hydraulik Power Unit

Estimated size: M = 100l Liters of Oil

Hydraulic Power Unit in compact design, completely pre-mounted and painted, to be placed nearby the turbine.

Functionality: The operating pressure will be worked off from the pressure accumulator until the minimum pressure is reached. Only if the working pressure falls below the minimum pressure the accumulator will be refilled by the pump. The pump will shut off as long as the pressure in the accumulator is high enough to avoid overheating and overpressure and increase pump lifetime. In powerless state the pressure can be build up with a manual pump to actuate the hydraulic cylinders. Biodegradable oil can be used on request.

The pump consistst of the following main parts:

- Pressure Switch for the pump control
- Pressure Accumulator with saftey pressure switch
- Oil tank with filler neck
- Oil drain plug
- Vent filter
- Oil level inidicator
- Temperture switch
- Visual and electrical oil level control (alarm)
- Return flow filter
- Pressure filter
- Manual pump (to start up machine in powerless state)
- Gear pump
- Three phase motor 400V
- Pump check valve and overpressure valve



Hydraulic Power Unit tailor-made by WWS Wasserkraft according to turbine specifications!

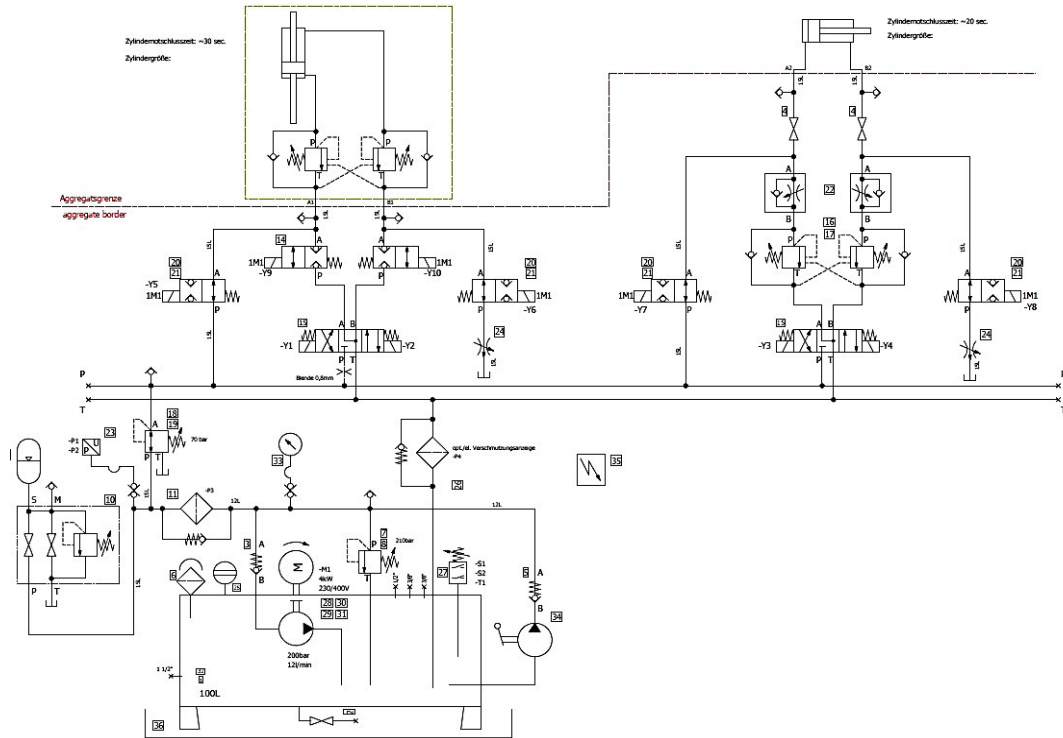

6 Automatic Grease Pumps

Make: LINCOLN Quicklube©

Current: DC

Voltage: 12V

Lincoln Quicklub centralized and automatic lubrication systems

A automatic greasing pump has the advantage to constantly pump the required amount of grease to the sealing, instead of a daily or weekly peak. In addition a maintenanceless operation is ensured (refilling only every 4-8 month).

These pumps are electrically operated and are used in progressive-type automated lubrication systems. The proven and reliable P203 pump has been designed to develop high operating pressures allowing it to supply NLGI #2 grease in most ambient temperatures. Versatile, compact and economical, this pump can be enhanced with several options including an integrated controller, low-level monitoring and system monitoring.



7 Technical Documentation

Detailed technical documentation of the whole equipment in English language and colour, submitted to the customer as printed version after commissioning. Containing the latest settings and values of the equipment. Including the following documents:

Operating Manual
Maintenance Manual
Installation Drawings
Assembly Drawings
Testing Protocols
Hydraulic Scheme
Wiring Diagrams
Spare Parts List
Manuals of purchased parts



8 Basic Consultation

WWS Wasserkraft will give you support in the development of your hydro power plant project **free of charge** based on our long-standing experience :

- Support in design of intake and power house
- Consultation on site
- Calculation of annual production according to yearly flow diagram
- Customized design of equipment



9 Protection Covers & Railings

Covers and Railings made for ducts, shafts and rotating parts or other areas and parts that need to be protected accordingly. For example belt transmissions, turbine shafts, deep ducts, ect. Executed according to the CE machinery directive 2006/42/EG .



C Electrical Equipment

1 Turbine Control & Protection System including control cables and wiring

Operation Principles

Default settings:

Turbine control and protection system optimized for a double regulated WWS Kaplan open flume turbine in modular design. The control system is developed for reliable and unattended operation and assures fully automated running mode and well as a manual control mode for feeding the generated electricity into the main grid. The machine can be managed and controlled via a HMI-touch panel in the power house. All fault messages are collected in a sum report and indicated on the screen and in case the machine will be brought into a safe mode. The measured values necessary for operation and icons of all machine elements are shown graphically on the HMI panel. The machine sets are started, synchronised and turned off automatically as defined by a respective control command (process control). Furthermore it is possible to have remote supervision via SCADA system.

Adjusting and Re-starting:

It is guaranteed that the plant is automatically stopped without any external power source in the event of the failure of a preceding net or an emergency stop or adjustment command as a consequence of inadmissible operational states from the turbine or the electrical equipment.

If the plant has been stopped through an external failure it is automatically re-started after the re-start of the preceding net.

If the plant was stopped due to an internal failure it remains blocked. After the failure has been eliminated operability is secured without any special measures and the plant can be re-started either automatically or manually.

Elimination of risks:

The closure of the shut-off organ happens independently from external energy and is secured through stop valves in closed current mode and/or closing weights.

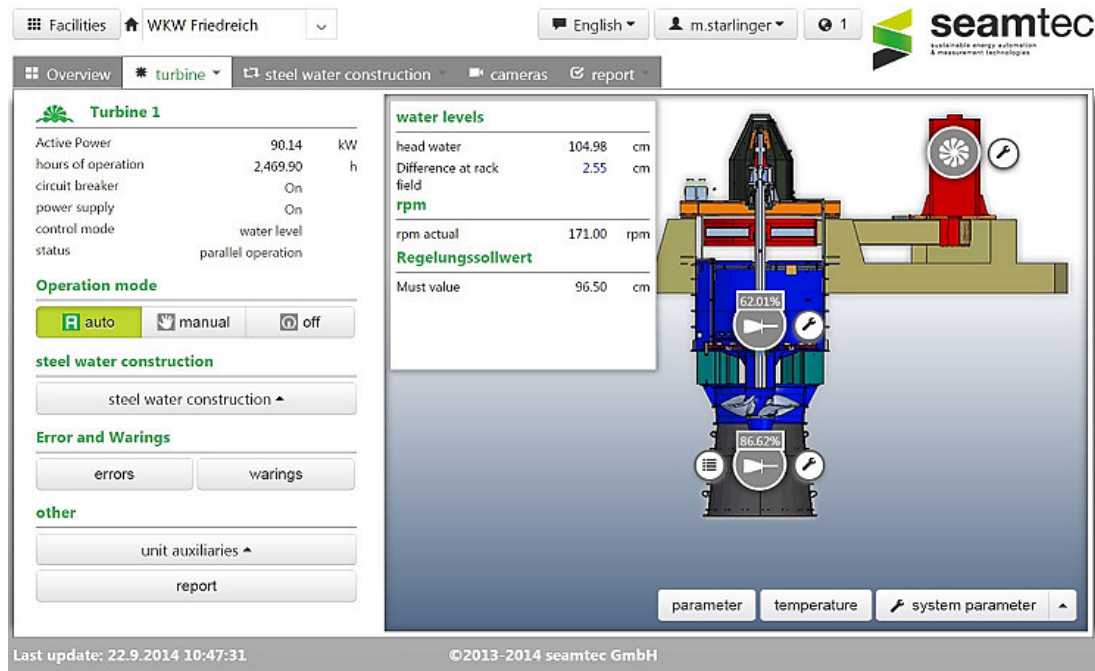

Operating Modes:

Automatic Mode:

The turbine starts automatically and synchronizes with the main power grid. In case of failure or power break down the turbine will shut down automatically until failure is fixed or power in grid returns. Then the machine will be restarted and synchronized with the main power grid.

In automatic mode following control modes are available:

Water Level Control:

Via a water level sensor the turbine will process the adjusted amount of water.

Flow Control:

The turbine will work on a preset discharge volume.

Output Control:

The turbine will work on a preset nominal output.

Manual Mode:

In manual mode it is possible to control wicket gate and other control elements manually via the touch panel.

Technical Data:

Supply Voltage: 230/400V
System Voltage: 24V DC
Surge Class: CAT III
Current: 63A
Isolation Class: IP55
Color: RAL7035

15" Multitouch Panel PC
B&R X20 CPU
B&R X20 modular I/O system
B&R X20 digital outputs 24VDC, 0,5A
B&R X20 digital inputs 24VDC
B&R X20 2 analog inputs (4-20mA)
B&R X20 8 PT100 temperatur inputs



1 Control Unit Cabinet (800x2000x600)
Make: SEAMTEC
TYPE: RITTAL TS8
Protection Class: IP54

Approbations TS8 Control Cabinets:

UL	Russian Maritime Register of Shipping
CA	Lloyds Register of Shipping
TÜV & TÜV Mark	Bureau Veritas
VDE	Germanischer Lloyd

The control unit fulfills the following tasks:

- Automatic starts and stops the turbine
 1. Single step control
 2. Reporting of start-up readiness
 - 3 . Step display
- Fault indication systems: temperature control, limit switch control, pressure switch control
- Auxiliary drive operation control
- Water way control
- Station service control: Control of transformers, AC/DC supply system, medium voltage system
- Touch Panel (HMI)
- Automatic stop and start-up procedure executed as a process chain:
- Turbine governor system

Synchronisation & Basic Protection System:

Before switching the generator into the net a automatic voltage equalisation is carrier out. The generator may only be switched on within and adjustable admissable voltage difference. Additionally an automatic frequency equalization guarantees a quick approach of the turbine to the nominal rotation speed (rpm).

Make: B&R
Type: CM0985

The CM0985 has a compact size and combines a power measurement module that has special features with a synchronization unit that is able to meet all demands.

- Energy measurement for 120 - 480 VAC
- Simultaneous measurement of two AC networks plus two additional voltages
- For multifunctional measurement tasks
- Intelligent mains network synchronization unit

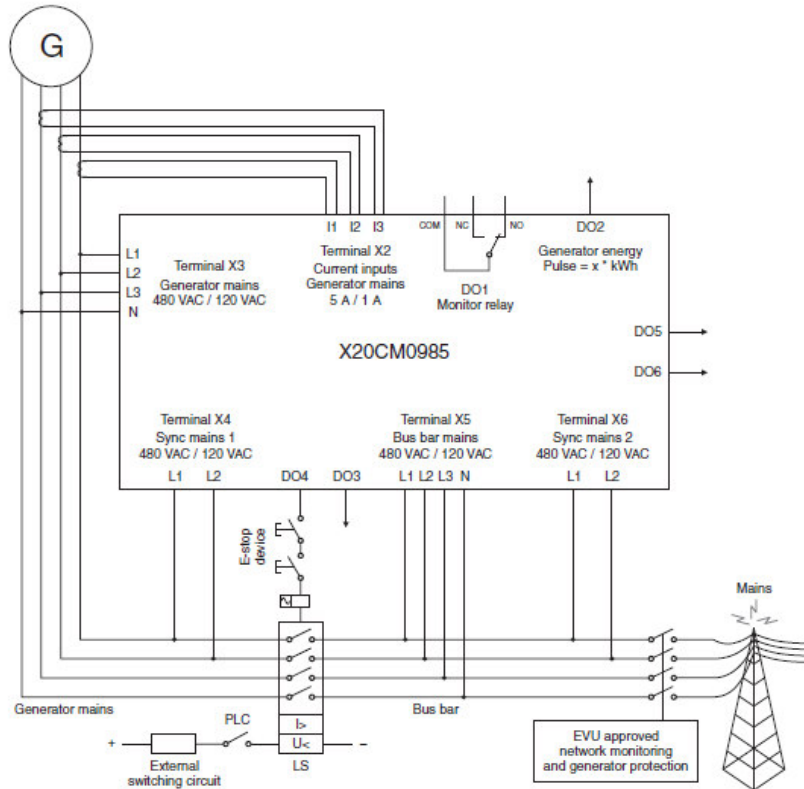

In the measurement unit, the three current inputs are suitable for both X:1A and also X:5A current transformers. The excellent overcurrent resistance as well as the high resolution of the measurement unit round off the features. For the voltage inputs, the value range can be configured between 480 VAC and 120 VAC.

The area of use includes 4-wire AC networks with a phase voltage up to 480 VAC and 3-wire systems, whereas L2 can be grounded (V-connection). The module can also handle an Aron measuring circuit.

The resulting measurement values range from pure phase current and phase conductor/line voltage to active current, reactive current and apparent power components, mains frequency, power factor and much more. Additionally, peak values and work counters are saved on the module in nonvolatile memory. Depending on the configuration, a digital output with scalable rating can also be used as pulse encoder for an external energy meter.

The synchronization unit not only takes the phase position and phase voltage into consideration, built-in intelligence also takes the change speed and other parameters into consideration and allows them to influence the decision for switching the synchronization output. Monitoring of a generator is possible with a large number of additional conditions. A total of four voltage inputs provide the needed flexibility.

Monitoring functions extend the features of the module. Rating-dependent over-current monitoring is included, which uses the thermal capacity of the motor/generators to allow short overloads and still provides full protection. Dependent delayed unbalanced load monitoring, which is used to protect three-phase producers and three-phase networks from an unbalanced load, can be adjusted to the characteristics of different generator types using parameters while taking its special thermal time constants into consideration.

Protection integrated into the turbine software:

- Temperature Protection (stator, bearing, winding)
- Over/Under Voltage Protection (ANSI 27/59)
- Over/Under Frequency Protection (ANSI 81)
- Overspeed Protection (ANSI 12)
- Overload Protection
- Equalizing Current Time Protection
- Out-Of-Balance Protection (ANSI 60)

- Protection against too Low-Excitation (ANSI 40)
- Protection against Reversed Power Flow (ANSI 46)
- Stator Grounding Protection -> Option (ANSI 64)
- Protection against Generator Differential Fault -> Option (ANSI 87)

2 Low Voltage Switch Syst.

The entire low-voltage switch system is installed in capsulated cabinets

Switchboard	400,00 V
--------------------	-----------------

Electrical characteristics

Rated voltage	V	690	
Service voltage	V	400	
Rated frequency	Hz	60 Hz	
Rated insulation level (one min. 50 Hz withstand voltage)	kV rms	1	
Surge category	CAT	III	
1 second withstand current	kA rms	65	
Peak withstand current	kA peak	187	
Busbar rated current	A	100	

Cubicles for 400V Low Voltage Switch System

Item	Type	Name	Switchgear Name	Substation Name	Quantity
1	CB	INCOMING CUBICLE	CB1		1
2	CB	AUXILIARY CUBICLE	CB2		1
3	CB	GENERATOR OUTGOING CUBICLE	CB3		1

Cubicles for 690V Low Voltage Switch System (when using a 690V Generator)

Item	Type	Name	Switchgear Name	Substation Name	Quantity
1	CB	INCOMING CUBICLE	CB1		0
2	CB	GENERATOR OUTGOING CUBICLE	CB2		0

* When using a Generator with higher voltage than 1000V it will be fed into the Medium Voltage Switch System

Scope of Supply for Low Voltage Switch System

3 LV switch system cabinets

with the dimensions: 1000x2000x600 mm
 Make: SEAMTEC
 Type: TS 8
 Protection class: IP 21

following components are included into a switching cabinet:

400/690V-distribution:

- 1 incoming circuit breaker NSX160
- 1 5-pol bus bar
- 3 current transformers 100/5 A Kl. 0,5
- 6 NH-switch with fuses
- 1 voltage protection device
- 1 clamps and accessories
- 10 3-pol. branches with auxiliary contacts



3 Main Power Transformer (Oil Transformer)

0 power transformers with following characteristics:				
- Rated power output (max.)	100	kVA		
- Rated voltage at primary side	--	kV		
- Rated secondary voltage	0,4	kV		
- Rated frequency	60	Hz		
- Vector group	Ydn5			
- Maximum ambient temperature	40	°C		
- Impedance voltage	4	%		
- PK (Short-circuit losses @ 75°C)	2,0	kW		
- P0 (No-load losses)	0,3	kW		
- Weight (Transformer + Oil)	1460	kg		
- Dimensions (LxWxH): ~	1200 x	720 x	1530	mm
- Hot Dip Galvanized (if by the sea)	Option	NO	€ 0	Prices of transformer will change accordingly.
- Buchholz Relay	Option	NO	€ 0	



3a Aux. Unit Transformer (Oil Transformer)

0 power transformers with following characteristics:				
- Rated power output (max.)	100	kVA		
- Rated voltage at primary side	0,4	kV		
- Rated secondary voltage	0,4	kV		
- Rated frequency	60	Hz		
- Vector group	Dyn5			
- Maximum ambient temperature	40	°C		
- Impedance voltage	4	%		
- PK (Short-circuit losses @ 75°C)	2,0	kW		
- P0 (No-load losses)	0,3	kW		
- Weight (Transformer + Oil)	1460	kg		
- Dimensions (LxWxH): ~	1200 x	720 x	1530 x	mm
- Hot Dip Galvanized (if by the sea)	Option	NO	€ 0	Prices of transformer will change accordingly.
- Buchholz Relay	Option	NO	€ 0	

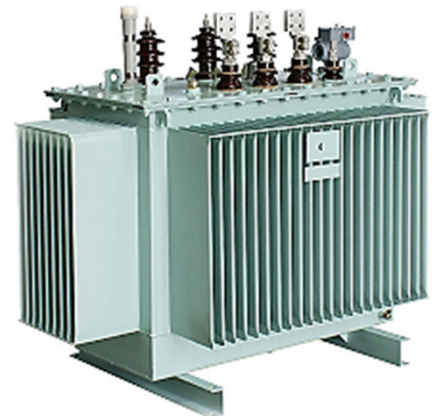

WWS uses leading European transformer brands with high efficiency.

Manufacturer: GBE - Italy, SBG - Germany, BARTH - Austria etc.

General Characteristics:

- Design according to IEC60076 & ÖVE EN60076
- Hermeticism Design
- Oil filler neck & drain plug accor. to DIN42553 & 42551
- Protection Class IP54
- Ambient Temperature: -25°C to +40°C

Included Equipment and Accessories:

- Cooling: ONAN
- HV & LV feed through made of Porcelain
- Mineral oil according to IEC60296 class 2
- Dial thermometer: 0 - 120°C
- 5-step diverter: operateable in powerless state

4 Med. Voltage Switch Syst. -- kVA

Switchboard -- kVA

Make: Schneider Electric - AUT; Driescher Wegberg - GER

Type: Flusarc 36, RM24, MINEX; GISELA

Electrical characteristics

Rated voltage	kV	--
Service voltage	kV	--
Rated frequency	Hz	60 Hz
Rated insulation level (one min. 50 Hz withstand voltage)	kV rms	70
Impulse withstand voltage (1.2/50µs wave)	kV peak	170 up to 1000 m
1 second withstand current	kA rms	16
Peak withstand current	kA peak	40
Internal arc withstand current (IEC 60298 app. A)	kA rms	16
Busbar rated current	A	630 at 40° C



Switch Cabinets & Cubicles for Generators 400V & 690V (Voltage below 1000V)

Item	Type	Name	Switchgear Name	Substation Name	Quantity
1	NE-DI	Compact Switchgear: Circuit breaker & cable outgoing cubicle	+A1		1

Switch Cabinet & Cubicles for 6,3kV Generators (Voltage higher 1000V)

Item	Type	Name	Switchgear Name	Substation Name	Quantity
1		Generator Cubicle	-		0
2		Auxiliary Cubicle	-		0
3		Meter / Measurement Cubicle	-		0
4		Outgoing Cubicle	-		0

Total quantity of cubicles necessary for medium voltage switch gear: **1** Cubicles

Size per Cubicle (BxHxT): ca. 600mm x 2000mm x 1100mm

General Characteristics:

- Metal-enclosed, air insulated switch gear
- SF6 gas-insulated switchgear for medium voltage power distribution up to 36kV
- It is designed for secondary substations on a ring or radial network of energy distributors and for wind-, water-, and photovoltaic power.
- Featuring gas insulated technology for an extended service life and very low maintenance costs even in harsh environments.
- The system offers a wide range of functions based on switch-disconnectors, vacuum circuit breakers, switch disconnector fuse combinations, earthing switches and metering units.
- The panels are designed for indoor installation
- The design of the panels corresponds to the specification of the IEC 62271

5 Battery Syst. & DC distribution 24V

Battery system for emergency operation of turbine control system with automatic charger, load control system and safety system.

Batteries:

1 battery system 24 V with maintenance-free lead batteries installed on a rack

Life time 10 years

Capacity 45 Ah

Charger and distribution

Regulated charger according to U-I-identity line

nominal current 20 A

24 V-distribution

- 1 DC distribution system with branches, protection systems, power and voltage display
- Decoupling Backup UPS Module
- Fused circuit breaker for the supply of the control panels

6 SEAMTEC SCADA Basic System (Supervisory Control And Data Acquisition - System)

Make / System: SEAMTEC SCADA

SEAMTEC SCADA System is a high tech - modular SCADA System and is optimized specially for hydro-power plant operation. The single control-entity are connected through the network and interact directly with the SCADA System. The system is based on a state of art high tech .NET Webapplication

Languages:

The system has multi-lingual-ability and can be used in desired language.

(German, English, Spansih, Russian, Rumanian, Turkish)

Protocols

- risk report protocol
- operation protocols (day, month, year, ...)
- hardcopies

The following functions are provided:

- Machine start
- Machine stop
- Choice of operating mode
- Adjustments of desired values (chosen values)
- SMS/E-Mail information and part-operation device -> Option
 - a) all Alarms are sent via SMS or/and E-Mails to maximal 5 numbers/adresses
 - b) you can confirm a Alarm with a PIN-Code, and if Problem is solved - the turbine will start automatically
 - c) you can check important values like: Power, water levels, openings,... via SMS or/and E-Mail

Images:

- First image
- Electrical overview with measured values
- Mechanical overview with measured values
- Overview water management (weir, pipeline, power house, ...)
- Temperatures
- Alarms
- Maintenance intervals -> Option
- Curves (values to be selected)

Archives (about 30 values)

- report recording (operating mode, opening positions, regulation parameters,...)
- Measurement recording (Power, Energy, Temperatures, Water levels,...)

All values are saved minute-by-minute within the first 24h.

After the first 24h every 15 minutes an average value of the last 15 minutes will be calculated and stored.

Additional to the 15 minutes average all atypical values are saved.

All values can be exported into a (excel-) file for further using.

Licences

All required licences (Microsoft license for server and workstation as well as SEAMTEC SCADA software license) are included.

Interface/gateway:

For interface of a external database management system there exist a OPC or a MODBUS interface -> Option

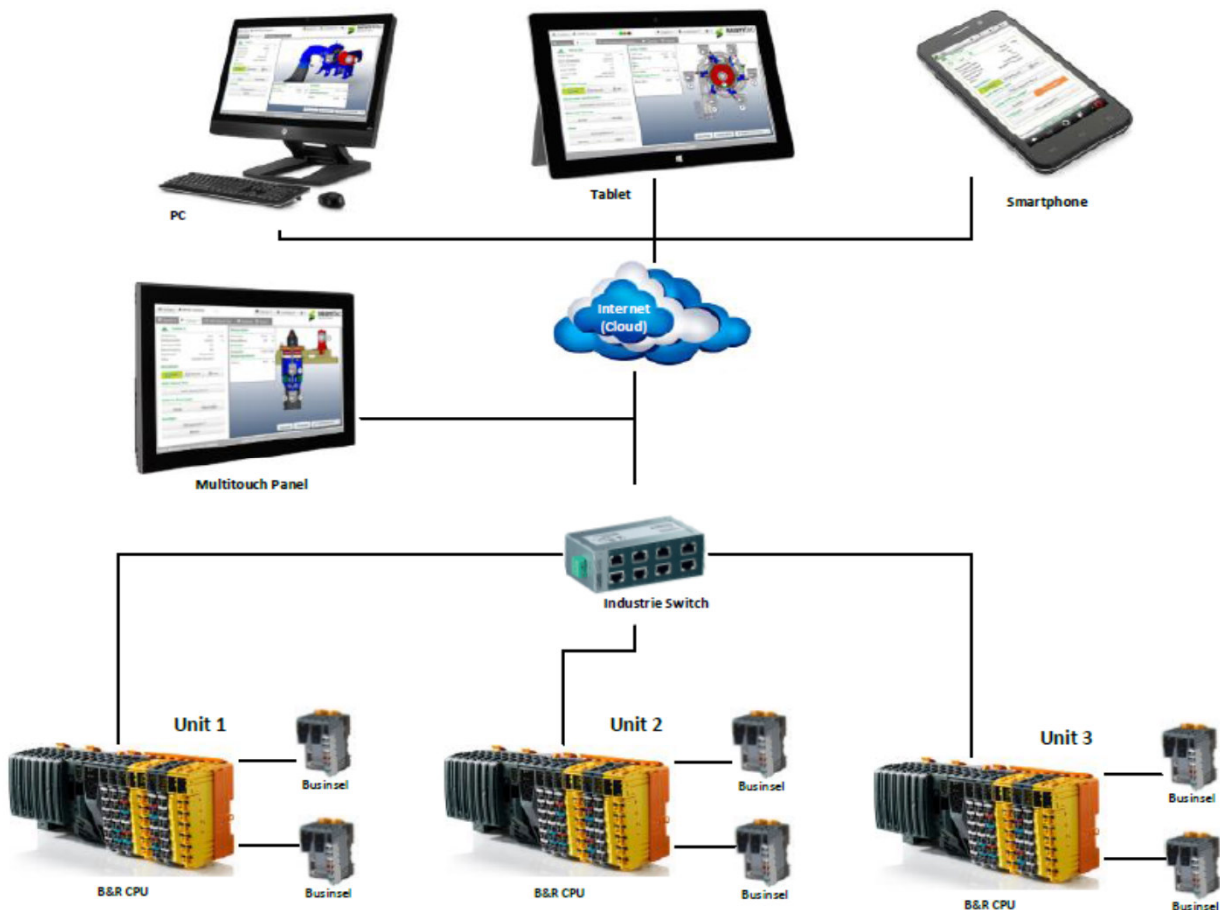

7 Fault Message Service

In case of an failure or warning a short text message can be sent up to 10 tepephone subscribers or cell-/smart phones. For this feature the system has to be connected to an internet access in the power house.

Note:

The DSL-Router for internet access in the power house has to support the following features:

- Port Forwarding (Port TCP80, TCP8060, UDP500, UDP4500)
- VPN (IPSec) Protocol

Another requirement is a fixed public IP-Address (IPv4) for remote access.

If the bandwith is below 512kb/s, or the signal is noisy, a proper operation or huge data transfer cannot be guaranteed therefore a high bandwidth data access is recommended!

8 Remote Operation

Combined with a digital turbine control system. In SEAMTEC SCADA System, an external access can be integrated. The Client only needs an Internet Browser (actual standard versions, e.g. IE11, Google Chrome). The remote access to the power house will be established over a VPN tunnel. This VPN tunnel provides a secure access between client and power house. With a remote control the machine can be managed and supervised via an external Client (e.g. laptop, tablet pc, smart phone) anywhere in the world als long as a stable internet connection is established.

9 Power Cable Set and Cable Trays

Cable Length: 10 m

Type: Will be determined after exact cable length and generator power are determinde

Including generator power cables from the generator to the low-voltage, medium-voltage switch system or transformers. The standard prize includes a cable length of 10m unless mentioned differently and needs to be elaborated exactly to submit a final offer. Cables are designed to transmit and withstand the max. load currents and power peaks. This also applies for all cable trays which are necessary to securely place the cables between the units.

10 Engineering & Documentation

Detailed electrical engineering and design of all circuits, switches and wiring as well as a documentation of all the electrical equipment implemented.

Documentations (2 series) consits of:

- 1-poled schematic
- Switchboard Diagram
- Circuit Diagram
- Equipment List
- Clamp Plan
- Cable List
- Release Diagram (protection)
- Description of the equipment
- Program Documentation (plc)
- Service & Operation Manual

Schematic Single Line Diagram:

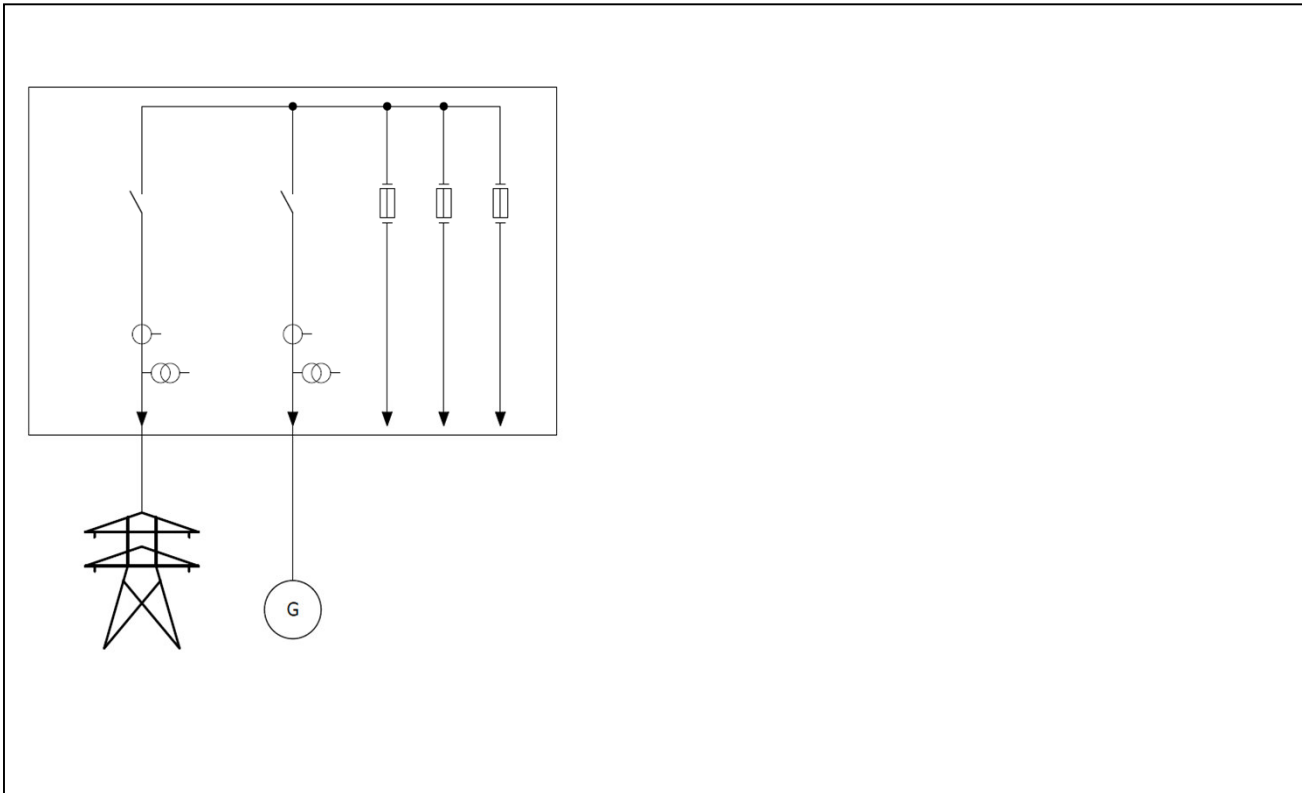

D Erection & Training

1 Erection on site

The erection is performed by WWS Wasserkraft personnel. The usual installation team consists of 2 mechanical engineers and up to 2 electrical engineers depending on scope of delivery. Our engineers are highly trained staff, having longstanding experience in the erection of hydro power plants and contributed to finish the work according to schedule. At least one of our workers will speak and understand appropriate English. Our workers will be equipped with basic hand tools and safety protection. Erection is made according to agreed time schedule which should include concreting and all other activities out of our scope that could affect the erection. All lifting devices need to be available according to schedule and during the defect liability period.

2 Commissioning and Training

The commissioning of our scope of supply is carried out by one mechanical engineer and one electrical engineer. The purpose of the commissioning is to check that all equipment supplied by WWS Wasserkraft is working properly and without defects. During this period all functions are tested and all alarms and events of the control system are carried out in the right way.

Training of customer and operators of the plant takes place during erection of the plant and during commissioning. This way the customer's staff will get already intense practical experience and time to get familiar with the system. In addition to the training during erection and commissioning we consider to 2-4 more days of training (as agreed) when the turbine is able to be started up and main work is finished.

3 Travelling Costs

Estimated expected costs for travel time, travel costs as well as flight tickets for installation time during a single phase installation. Accommodation for WWS workers will be arranged by customer.

E Packaging & Transport

Seaworth packaging, air sealed and packed in wooden boxes of all parts and equipment listed in the scope of supply, loaded and fixed on the truck, trailer or container to assure a safe and protected delivery of the product to the specified site.

Transport, if carried out by WWS Wasserkraft will be according to the ICC - International Commercial Terms using the **Incoterms® 2010** clause:

CFR – Cost and Freight (named port of destination)

Seller must pay the costs and freight to bring the goods to the port of destination. However, risk is transferred to the buyer once the goods are loaded on the vessel. Insurance for the goods is NOT included.

F Optional Equipment

1 Runner Blades made of 1.4313

On request the Kaplan runner blades can be also made out of stainless steel X3CrNiMo13-4 (1.4313) instead of the standard Aluminum-Nickel-Bronze casting (G-CuAl10Ni) to achieve highest wear resistance and life time.

2 Biodegradable Oil for runner hub

Make: Fuchs
Typ: PLANTOGEAR 320S

Plantogear S-Oils are environmentally friendly industrial oils on basis of synthetic components with high resistance to aging and excellent wear resistance. Plantogear S-Oils are used in very sensitive environmental areas as well as for lubrication of drives in water protection areas.

PLANTOGEAR S-series fulfill the following standards:

- DIN 51517-3:CLP
- ISO 6743-6:CKC

3 2nd Pump unit for HPU

Current: DC
Voltage: 230V

Second pump unit for hydraulic power aggregate to secure operation even when first pump unit errors out to maximize reliability of hydro power plant. Voltage and current selected according to customer's needs.

4 Humidity Absorbing Filter for HPU

Make: EATON
Type: BFD

The filter prevents the penetration of contamination from the ambient air in the hydraulic fluid. The circulating air contains particles and moisture that can cause corrosion, increase equipment wear, and reduce fluid performance. This humidity absorbing vent filter for hydraulic power units protects expensive hydraulic equipment from, raises reliability and reduces maintenance costs simply by:

- Preventing corrosion
- Prolonging the lifetime of hydraulic lubrication fluids
- Minimizing downtime, repairs and wear
- Extending the lifetime of regular oil filters

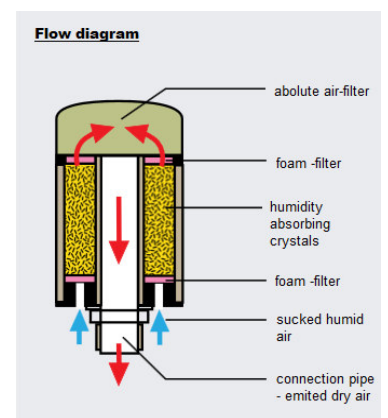

5 Proportional Valves for HPU

Make: Parker, Festo

Instead of regular valves for the HPU, electrical regulated and programmable proportional valves will be used. All electronic controller and wiring are included.

Technical features:

- Low hysteresis
- High reproducibility
- Load-independent oil flow
- 5 flow rates

6 Biodegradable Oil for HPU

Make: Panolin HLP SYNTH E

Based on saturated esters from natural resources combined with special additives. Fully synthetic and rapidly biodegradable high-performance hydraulic fluid.

Eco-Labels

PANOLIN HLP SYNTH E fulfills requirements as in:

- European Eco-Label
- Dutch Vamil Regulations – VROM
- Swedish Standard
- US Bio Preferred



7 Wicket Gate Monitoring

Electrical monitoring system for wicket gate position. Each guide vane is equipped with a sensor and adjusted to the correct position. If a guide vane gets misplaced for example due to piece of debris the sensor contact opens up and immediately an alarm is displayed notifying operators to correct the issue also showing the number of the guide vane to exactly identify the failure at the machine. This way plant reliability can be increased as efficiency will not be interrupted due to incorrect wicket gate adjustment and unnecessary vibrations can be avoided.

8 Bridge Crane incl. Rails

The steel structure of the crane is in accordance with DIN 15018, Lifting class H2, Loading group B3 - calculated. Designed as a box girder crane. Girder with two-sided slopes of 45° angle. The lower edge of the Crane girder is at the same height as the upper edge of the runway rail. The crane is designed for indoor operation in a factory hall similar building. Designed to be used at normal and ambient temperatures from -10 ° C up to max. +45 ° C. Crane with electric wire rope hoist, monorail hoist for low headroom method on the bottom flange of the crane girder.

Main lifting:	5,0 m/min 8,90 kW 40 % ED
Adjustment lifting:	0,8m/min 1,40 kW 20 % ED
Trolley continuously:	5,0-30,0 m/min 0,35 kW 60% ED

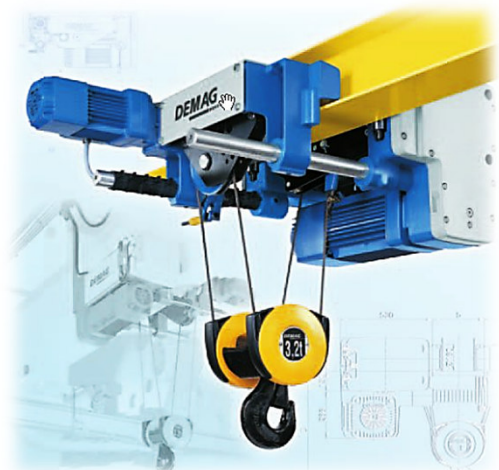

Trolley: 5,0/20,0 m/min 2x0,20/0,80 kW
Linkage: wired ground control moved the crane carrier
power supply: trolley power via trailing cable including grounding
Current: three-phase
Operating voltage: 400 V
Frequency: 60 Hz
Control voltage: 48V
Load control to protect the hoist from overload, type MGS, electromechanical mode of action.
Integrated load collective memory load spectrum.
Static calculation:
Will be performed according to needs and forwarded explicitly to the customer

Quality system certified to ISO 9001 - Permanent quality control
Brand: Demag Cranes & Components GmbH

9 SEAMTEC SCADA Enterprise System

The SEAMTEC SCADA Enterprise System is based on the SEAMTEC SCADA Basic System and is a professional solution for data acquisition programs that will support several new features and is recommended by WWS Wasserkraft to manage several hydro power plants from one workstation:

Additional Features: (Based on Basic Edition)

- Single Line Diagram of the entire plant with electrical data
- Extended Archive Functions (long term data saving and analysis with 6TB HDD)
- Energy Monitoring
- Optimized Hardware components for SCADA Enterprise System for 24/7 operation
- Power House ethernet network system to connect other PC's
- Internet Router for internet connection (Firewall function, VPN tunnel)

Scope of Supply:

- SEAMTEC SCADA Enterprise Edition License
- Workstation PC
- 24" LCD Display
- Color Inkjet Printer A4
- 19" Network Rack (min. 28 HE)
- 19" Switch (28 Port, 1Gbit)
- SEAMTEC SCADA Server (19" Rack)
- 150m Ethernet Cat6 cable
- Router

10 Condition Monitoring

Condition Monitoring simply increases plant availability and reliability .

The purpose of condition monitoring is to minimize machine down time due to error by noticing changes in the machine set or parameters in advance before they can lead to failure or breakage and response with a preventive action/ maintenance accordingly. Therefore maintenance costs can be reduced and the production can be maximized. Mainly this can be accomplished by the implementation of sensitive sensors on the machine sets.

Sensor technology and state of the art electronics combined with complex mathematical logics and constant recording of the actual machine status enables the possibility to identify bearing failure, increased vibrations, temperature rise and other changes in the condition in an early stage.

Advantages of Condition Monitoring:

- Machine components only need to be repaired or exchanged if really necessary
- Potential errors can be recognized at an early stage
- Due to the integration of Condition Monitoring into the operation process the reliability of the results and statements can be increased significantly.

Delivery includes:

- Condition Monitoring measuring card
- Vibrationsensors with 20m cable
- Software module for evaluation, implemented into the turbine software

11 Redundant CPU Solution

B&R's redundant control system concept ensures maximum availability for entire systems as well as individual machines, reducing down time and the involved economic losses as well as costs of repair. Master redundancy with POWERLINK synchronizes data with microsecond precision and can be switched over in a matter of milliseconds. This functionality is seamlessly integrated in the real-time operating system and extremely easy to use. A second identical Atom™ controller from the X20 standard product range is added to the existing control topology and configured as redundant via software. An interface module handles data exchange completely automatically. Configuration and visualization remain the same for the user. Maximum machine availability really is only a mouse click away.

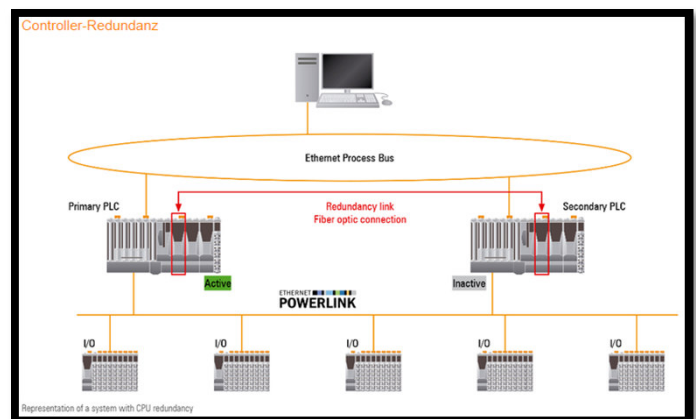

12 Monitoring Camera - Outdoor

2-Megapixel Day/Night PoE Outdoor Network Camera

Exceptional Image Quality

With built-in 3DNR (3-Dimension Noise Reduction) and WDR (Wide Dynamic Range) technology, the camera is able to filter the intense backlight surrounding a subject and remove noises from video signal. The result is that an extremely clear and exquisite picture quality can be produced even under any challenging lighting conditions.

Flexible Power Options

Featuring PoE (Power-over-Ethernet) capability, the device receives electrical power using Ethernet cabling from a PoE-PSE (Power Sourcing Equipment) device. Thus providing great cost savings by eliminating the need for additional power cables and outlets. In addition, this camera also supports power 12VDC/24VAC through an optional external power supply in case a PSE device is not available.

Free bundled 64-channel Management Software

The free IP CamSecure software allows you to monitor up to 64 IP cameras simultaneously on one screen to enhance scalability. For added convenience and flexibility, the software includes various advanced features such as scheduling recording, event alert, and much more. In addition, simply install our free iCamSecure App to your smartphone and connect to the PC with IP CamSecure software installed, you will easily turn your smartphone into a portable surveillance system for real-time monitoring and snapshot.



13 Camera Surveillance System up to 40 cameras

Standard Package: **3** Cameras

The Surveillance Station is a professional network surveillance Video Management System (VMS).

Live view:

Maintaining accessible and reliable live surveillance feeds is essential for properties such as retail stores, hotels, construction sites, offices, and at home. With the Surveillance Station, you can easily manage & monitor multiple IP cameras on a real-time basis through web browsers, and attain the first-hand status of monitored corners, such as building gates, office entrances, or emergency exits, safeguarding your staff and property.

Recording:

The Surveillance Station provides flexible options to set up IP camera recording, including video format, frame rates, schedules, smart recording, and more.

High quality codec recording:

The Surveillance Station supports H.264, MPEG-4, M-JPEG, and MxPEG recording, ensuring high-quality recording videos for future playback and reference.

Features:

- Smart recording
- Scheduled recording
- Alarm recording

Playback:

The Surveillance Station provides various ways for you to search and analyze recordings so you can efficiently look up the desired events.

Features:

- Intelligent Video Analytics (IVA)
- Real-Time watermarking

Management:

The Surveillance Station provides flexible options for you to set up a surveillance system that is fully customized for you.

Web-bases user interface

The management of IP cameras is all done on the browser. With no additional software required, you save more time for other more important tasks.

Technical Data:

- 6 TB (HDD) (Raid 5)
- Intel Core Processor
- 4GB RAM
- 2 x 1GBIT RJ45 Ethernet Port

14 Weather Station

The weather station will give detailed information about the current hydrographic situation on site. Up to 4 temperature sensors can be implemented into the SEAMTEC Software such as room temperature, outside temperature and water temperature. Additionally all temperature data will be stored and the actual temperature value is visible in the graphical user interface. With the water temperature sensor it is also possible to activate trash rake and slice gate heating elements automatically. Furthermore a rain sensor is implemented to show actual precipitation on site. Another option is the integration of up to 8 smoke detectors into the turbine software.

Scope of Supply:

- 4 temperature sensors (2 indoor, 1 outdoor, 1 water)
- 2 smoke detectors (alarm integrated into control system)
- 1 rain sensor
- 15m cable per sensor
- Installation and commissioning

Features:

- Display of all temperature and precipitation values
- Digital storage of all data
- Report with data analysis

15 Additional Water Level Sensor

Piezoresistive Pressure Transmitter:

Make: Keller

These pressure transmitters are designed for level measurements where the highest accuracy is required.

This Series is based on the stable, piezoresistive transducer and a micro-processor electronics with integrated 16 bit A/D converter. Temperature dependencies and non-linearities of the sensor are mathematically compensated.

This probe is fitted with durable cable with an integral vent tube to the atmosphere.



16 Smoke Detector - Power House

Smoke Detector implemented into turbine control system. In case of smoke detection alarm will be triggered giving a loud beeping sound as well as a alarm will be displayed on the screen shutting down the machine and fault message will be send to mobile phone recipient. If implemented to local alarm system a direct information of the local emergency station such as fire fighting station can be send to minimize response time.



17 Electrical Installation - Power House

Includes the complete inhouse electrical installation for the power house, such as light, power sockets and light switches. To calculate working effort for our electricians a drawing of the power house including electrical specifications and quantitie of switches, power sockets, light sources and cable length needs to be specified in advance.

18 Ventilation System - Power House

Standard ventilation exhaust to purge air into the power-house and thereby remove excess thermal energy from generator and other heat inducing machine components. Not designed to cool the powerhouse lower than outside temperature. Designed for continuous operation.

Flow: 3800m³/h

Power: 240W

Temperature: -35°C to +40°C

Noise level: 75dB/1m



19 Temperatur Sensor - Power house

PT100 Indoor Temperatur Sensor implemented into control software.
Including wall mounting and vented housing for accurate temperature reading. For indoor use only. Temperature range 0°C to 70°C.
Accuracy according to IEC 751 class B

20 Generator Neutral Cubicle

&

21 Neutral Grounding Resistors are used in order to limit maximum fault current to a value which will not damage the equipment in the power system, yet allow sufficient flow of fault current to operate protective relays to clear the fault. Although it is possible to limit fault currents with high resistance Neutral Grounding Resistors, phase to ground short circuit currents can be extremely reduced. As a result of this fact, protection devices may not sense the fault. Therefore, it is the most common application to limit single phase fault currents with low resistance Neutral Grounding Resistors.

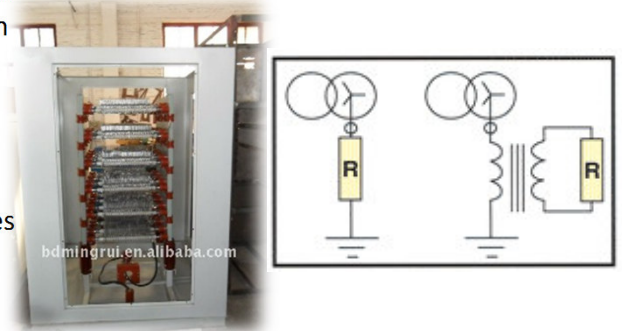

22 Diesel Generator

Emergency diesel generator set 59,8 kVA with DEUTZ diesel engine 1500 rpm
Model: DEUTZ GSL 65D - stationary execution, sound-dammed in accordance with CE standard, with switchbox for manual and automatic operation

Engine: EUTZ BF4M 2011C - oil cooled 4 in line cylinders diesel engine

Generator: brushless exciter design with solid state

Synchronous Generator: **60 kVA**
Continuous Output: **60 kVA** **48kW** at $\cos(\varphi)=0,8$
Supply Voltage: **400V** (230/400V or 208/480V)
Frequency: **60 Hz** (50 or 60Hz)
Dimensions (LxBxH): 2285 x 920 x 1150mm
Weight: 1093kg
Capacity fuel tank: 90l



23 Detailed QA/QC Protocol

Complete Quality Assurance and Quality Control Protocol from WWS Wasserkraft manufactured parts as well as from all parts delivered by subcontractors (such as generator, bearings, pumps ect.). A comprehensive audit record including testing protocol, measurement protocols, test certificates, testing procedures, tolerances of all parts and showing part standards according to DIN, EN, ISO ect. to assure highest quality standards of our products.



G Spare parts

1 Spare Parts Turbine / Main Valve

- 1 seal kit
- 1 set gaskets and seals
- 1 shaft sealing element
- 1 clamping set for each type which are used
- 1 set replaceable seals for butterfly valve actuator
- 1 set position transducers
- 1 set greasing for sealing
- 1 pc. Clamping torque for each installed type

2 Spare Parts Generator

- 1 Voltage regulator with power factor regulator
- 1 set fuses, rectifiers and varistors
- 3 pc. bearings
- 1 filling grease for one year
- 1 shaft sealing element
- 1 set PT100 sensors for bearings
- 1 set PT100 Sensors for windings
- 1 pc. Speed sensor

3 Spare Parts (Governor, Hydraulic power unit)

- 2 set of oil filters for one year
- 1 set of seals for each used typ of actuator
- 1 emergency closing valve
- 1 control solenoid valve
- 1 pressure sensor
- 1 oil level sensor
- 1 filling used oil
- 1 bubble for pressure accumulator
- 1 set sealings



4 Spare Parts Electrical Equipment

- 1 water level sensor
- 1 surge arrester
- 1 mains circuit breaker
- 1 multifunctional power meter
- 1 generator circuit breaker
- 1 auxiliary contactor
- 1 protection, metering and synchronization relay
- 1 differential protection relay
- 1 contactor
- 1 battery charger
- 1 multipanel touchscreen
- 1 PLC CPU
- 1 micro memory card
- 1 digital input/output modules
- 1 analog inputmodule
- 1 Ethernet module/switch
- 1 isolating converter
- 1 synchronoscope

H M & S Package

1 Maintenance Contract

- Verification of all fittings are tight
- Testing of storage (vibration measurement, running noise)
- Removal of old grease from the sealing
- regreasing with original grease
- replace of all necessary wear parts (f.e. sealings, ...) - original WWS Wasserkraft wear parts® included in price
- Leak Check and lubricate
- readjusting of the mechanical mechanism (wicket gate, ...)
- Wheel control cylinders checked for concentricity and tightness, adjust as necessary
- Check the runner and the adjustment parts for wearing and analyses the water

Generator:

- Check the smoothness
- Remove old grease from bearings and regrease
- Check the screws
- Check the cable connections are secure
- Check cooling system





Hydraulic power unit:

- test of hydraulic power unit
- Changing of filters
- check the oil quality and if necessary change oil (without import tax of oil)
- Check the pressure accumulator (nitrogen filling if necessary)
- All fittings and pipes for leaks
- Valve functions (emergency shut udgl.) Control

Electrical equipment

- funktion test of electrical equipment and if necessary changing of defect parts
- adjusting of parameters according expirience

2 Service Package Standard

-  in combination to a maintenance contract **one additional year warrenty** (maximum 5 years)
-  maximum **192h** after written claim for an deffect start **reparation** in warrenty chase
-  free of charge **service hotline** from 07:00 till 18:00, Monday till Thursday
-  **remote controll support** from 08:00 till 16:00, Monday till Friday

3 Service Package Premium

- 👍 in combination to a maintenance contract **one additional year warrenty** (maximum 5 years)
- 👍 maximum **120h** after written claim for an deffect start **reparation** in warrenty chase
- 👍 **24h service hotline**
- 👍 **yearly update** of software-source code
- 👍 **remote controll** support from 07:00 till 18:00, daily

4 Service Package All Inclusive

- 👍 in combination to a maintenance contract **one additional year warrenty** (maximum 5 years)
- 👍 maximum **72h** after written claim for an deffect start demounting or **reparation** in warrenty chase
- 👍 main **spare parts** stored at WWS Wasserkrafts warehouse
- 👍 **24h service hotline**
- 👍 3 weeks/year **operating** of the plant (f.e. during illnes or vacation)
- 👍 **loss of profits insurance with maximum of 3.000 EUR/anno**
- 👍 **yearly update** of software-source code and saftey update
- 👍 **remote controll** support from 07:00 till 18:00, daily

V TURBINE MEASUREMENTS (preliminary)

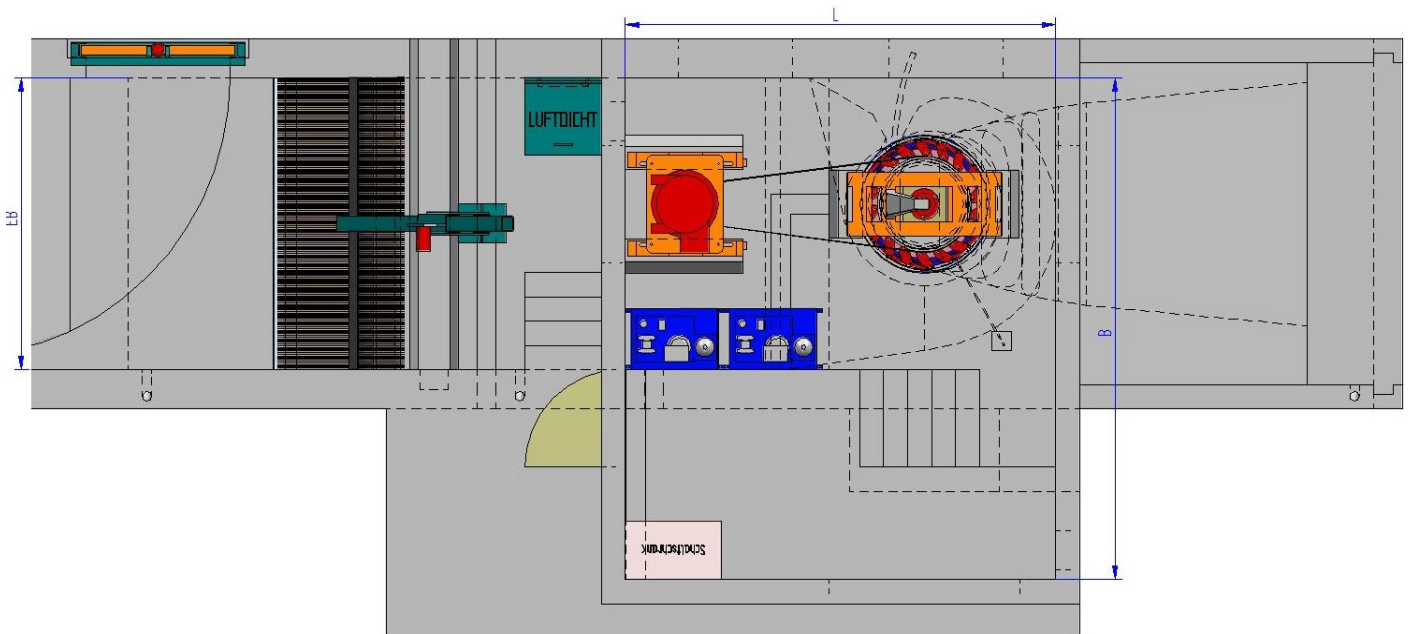
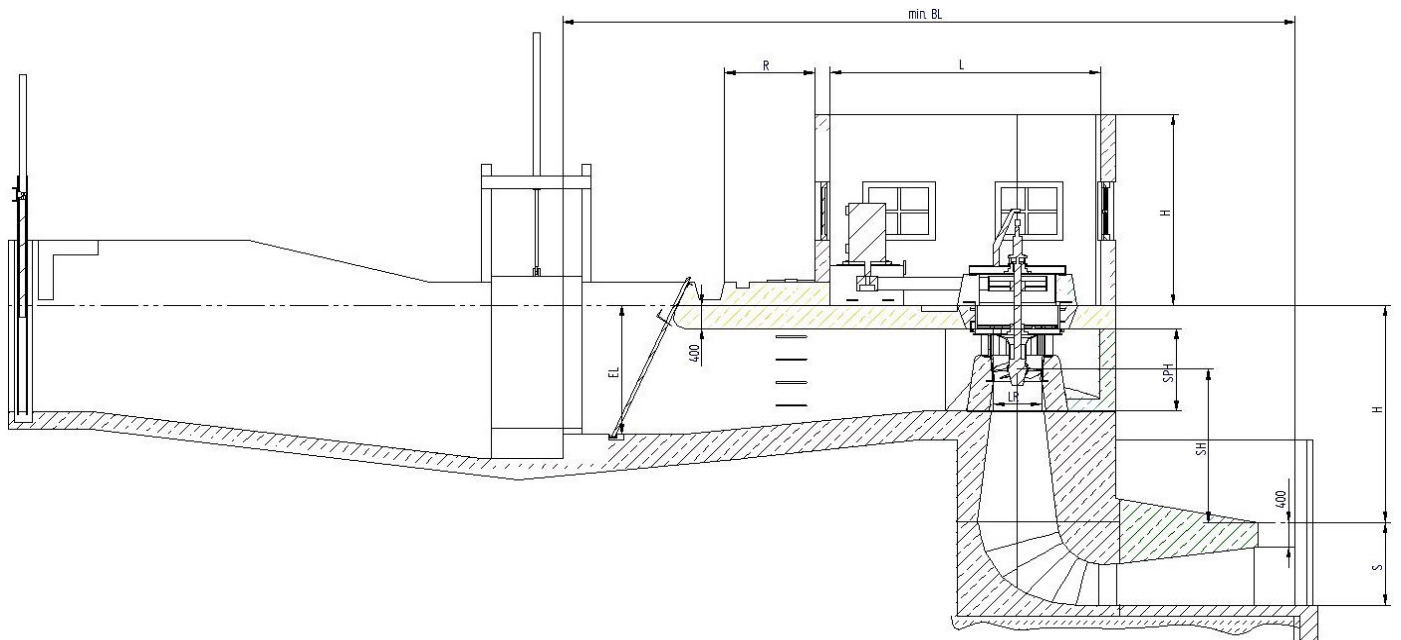

Turbine:		
LR \emptyset	Runner diameter	600 mm
H	Net Head	1,36 m
SH	Suction head	0 m
SPH	Spiral chamber height:	1050 mm
S	Tailwater Depth:	900 mm

Power House:		
H	Height Power House:	3000 mm
B	Width Power House:	2100 mm
L	Length Power House:	3000 mm
EB	Width Trash Rake:	1500 mm
BL	Total Length Power House:	6000 mm

Inlet Channel:		
EL	Inlet Height:	455600 mm
EB	Inlet Width:	1800 mm

VI TERMES OF PAYMENT

For 100 % of the Total Contract Price an irrevocable and confirmed Letter of Credit shall be opened and confirmed by a First Class Austrian Bank in favor of WWS Wasserkraft GmbH & Co KG on the agreed contract start date. For this WWS Wasserkraft GmbH & Co KG will submit a draft of an L/C.

Hence the payment will be made as follows:

40% of the Total Contract Price shall be paid in advance at sight against presentation of following documents:

- Down Payment Invoice stating 40% of the Total Contract Price

40% of the contract is due upon against presentation the following documents

- Commercial Payment Invoice stating 40% of the Total Contract Price
- Packing List
- Sender's copy of CMR

15% of the contract is due upon against presentation the following documents

- Commercial Payment Invoice stating 15% of the Total Contract Price
- Commissioning Certific
- In case the unfavourable circumstances stated in "Official Acceptance" last for more than three months, the final payment of 20% of the Contract Price automatically becomes due after the expiry of three months from the date of the freight document without the necessity of presentation of a Certificate of Commissioning or Provisional Certificate of Commissioning.

5% of the contract is due upon after 4 weeks test run

- Commercial Payment Invoice stating 5% of the Total Contract Price
- Final Commissioning Certificate (FCC)

If any additional works are necessary at site these shall be paid immediately after successful commissioning against presentation of the Invoice. The amounts of the payments are to be transferred immediately as the full amounts stated in the invoices without deduction of any fees. The Buyer will assume all bank fees regarding the opening and confirmation of the Letter of Credit as well as bank transfer fees.

VII TIME OF DELIVERY

The Contract comes in Force after the receipt of the downpayment and the Letter of Credit over the agreed
A detailed timetable will be agreed with the Employer. The below mentioned time of delivery serve as a rough

<input checked="" type="checkbox"/>	4 weeks after receipt the down payment:	Installation drawings
<input checked="" type="checkbox"/>	6 weeks after receipt the down payment:	Jacket tubes for the conduits and recesses for concret works
<input checked="" type="checkbox"/>	10 month after receipt the down payment:	Installation Parts
<input checked="" type="checkbox"/>	12 month after receipt the down payment:	Turbine Generator and runner are ready for dispach
<input checked="" type="checkbox"/>	after below conditions:	Assembly work on site
	<input checked="" type="checkbox"/> After the date of delivery of undamaged equipment at site.	
	<input checked="" type="checkbox"/> Total erection of civil works are done as per drawings set,	
	<input checked="" type="checkbox"/> Manual crane in operation.	
	<input checked="" type="checkbox"/> Energy supply as: HV line charged	
	<input checked="" type="checkbox"/> Availability of water in the river (full or part flow up to 30 %	
	Works at site like assembling, installation and adjustment for the concrete works and commissioning: Start within 2 weeks after the Employer's written notification of when installation can begin.	
<input checked="" type="checkbox"/>	Finishing all wiring (including power cable), pipeline work and concret work	Commissioning and training

In case of unforeseeable circumstances or circumstances beyond the control of Contactor and its sub-suppliers, such as all cases of force majeure, which impede compliance with the agreed period of delivery, the latter shall be extended in any case for the duration of such circumstances; these include in particular armed conflicts, official interventions and prohibitions, delays in transport and customs clearance, damages in transit, shortage of energy and raw materials, labour disputes, defective goods of a larger or important piece of work, default on performance by a major sub-supplier or sub-contractor.

VIII CONTRACT CONDITIONS

CHAP. 1) SCOPE OF SUPPLY

The scope of supply is limited to the Contractor's scope mentioned in the Contract and the confirmation order. Supplies and performances are strictly limited to conditions and descriptions specified in present technical specifications and the general terms of contract.

CHAP. 2) DEFINITIONS

Contractor – WWS Wasserkraft GmbH & Co KG
Employer – Contract partner, which orders the Equipment
FAT – factory acceptance test (before delivery)
PMCC – provisional mechanical commissioning certificate (after
PECC – provisional electrical commissioning certificate (after installation)
PIO – putting into operation
CC – commissioning certificate (after PIO)
FCC – Final commissioning certificate (after the test run)

CHAP. 3) INTELLECTUAL PROPERTY RIGHTS

The copyright on the design of products and services making the object of present contract belongs to the contractor according to the law in force.

The use and exploitation of services provided by the contractor doesn't generate copyrights for the employer.

CHAP. 4) CONFIDENTIALITY - RECIPROCITY

The Contractor will keep confidential all information regarding the fulfilment of the objective.

The Employer will keep confidential all information stated in the technical documentations, procedures and technologies used by the Contractor throughout the validity of the contract.

The Employer and the Contractor will keep confidential all provisions stated in the offer and the contract.

(1) One contracting party isn't entitled, without having the written consent of the other party:

- a) to reveal the contract or any other provision stated in it, to a third party, besides those persons involved in fulfilment of the contract;
- b) to use the information and the documents obtained during the progress of the contract, in other purpose than the one of fulfilling its contractual liabilities.

(2) Revealing of any information to the persons involved in fulfilling the contract, shall be made confidentially, and will be extended only to those information required to perform the contract.

A contracting party will be exempted of liability for revealing the information regarding the contract, in case that:

- a) the information was known by the contracting party before being received from the other contracting party; or
- b) the information was revealed after being obtained the written approval of the other contracting party for such revealing; or
- c) the contracting party was legally bind to reveal the information.

CHAP. 5) WEIGHTS

The weights of the equipment and the shipment will be stipulated after the detail design work is done. Any indication of weight is not binding until release of the final installation plans. The heaviest weight indicated forms the basis for the dimensioning of the temporary hoists and the cranes necessary for unloading, heaving of the equipment into the relevant installation place and installation of the equipment.

The total weight of the plant and packing will be notified to the Employer. To neglect the weight of the plant and packing when received by the Employer is an omission of duties and all claims of any kind correlating to the weight are excluded.

CHAP. 6) QUALITY CONTROL - INSPECTION, TESTING AND TRAINING

Quality control, inspection and testing during the manufacturing, erection and prior to the commissioning of the plant, will be mandatory. All equipment is manufactured under strict European quality control procedures. The Contractor will carry out inspection and control of technical specification, designed parameters throughout the manufacturing of the equipments.

Before dispatch, the equipment will be examined by the Contractor and sent only after successfully passing the test. The examination procedure and the test schedule are to be provided by the Contractor at the time of signing of this Agreement. The tests carried out are to be notified to the Employer two weeks prior to the tests and the FAT should be dispatched to reach the Employer two weeks after the test. The Employer is free to participate at this tests at his own expense.

The following procedure will be applicable:

During the manufacturing:

The Contractor shall carry out the quality control and the examination in accordance with the Contractor's quality control practice and the quality control program.

During the erection /

The Contractor shall furnish the Employer with the usual erection and installation instructions and the relevant drawings in order to be able to inspect the shipment.

The Contractor will inform the Employer about finishing the plant and all parts and readiness for packing.

CHAP. 7) TRANSPORT AND LIFTING

The costs for transportation which are not covered by the terms of delivery (e.g. transport from the port to the installation site), temporary liftings and other equipment needed for the unloading of the truck at site and the heaving of the equipment into the relevant installation place have to be provided by and are to be borne by the Employer.

CHAP. 8) ASSEMBLING AT SITE

Equipment delivered by the Contractor to the place of delivery has to be transported by the Employer at his own expense to the site and is assembled by the Contractor according to technical specifications at the site. Before assembly the Employer shall install the working crane, necessary electricity for the site given due notice by the Contractor and finish the necessary construction work, so that the assembling of all units be performed at the same time or one after the other, without time interruption.

CHAP. 9) CONDUITS, GENERATOR EARTHING AND CONCRETING WORKS

All the following conduits are not included in WWS Wasserkraft's scope of delivery.

The Employer has to provide:

- three-phase current connection with zero wire needed during the installation
- chase, base and anchoring plates in the building construction according to WWS's details
- empty and protective pipes, channels and pits needed for the installation of the connecting and joining cables for the turbine, generator, governor, water level transducer, hydraulic aggregate etc.
- If the generator star point is need to be earthed to provide the protection required additional components and installation of same must be attended without any additional cost for the contractor.
- all power cables (if not ordered in point D7)

CHAP. 10) CONTRACTORS RESPONSIBILITY

The Contractor has to build the turbine corresponding to this contract to comply with all specifications predetermined by the Employer and by the administrative decision and all other official guidelines and regulations regarding construction and safety of the turbine. The Contractor is not responsible for the sound intensity of the turbine in service.

CHAP. 11) EMPLOYERS RESPONSIBILITY

The Employer is liable for all construction work and possible measures to comply the administrative decision regarding the maximum sound intensity of the turbine tolerated by the administration, the provision of national law and regulations. Claims of any kind regarding the sound intensity of the turbine are excluded.

The Employer is responsible for the safety and health of the Contractor's employees working on the site erecting and commissioning the plant. The Employer is liable to conduct all reasonable provisions for safety and health at the site. Especially the Employer is liable to protect the employees of the Contractor in case of rebellion, revolution, riot, armed industrial dispute etc. and has to guarantee a safe accommodation or departure to Austria.

CHAP. 12) INSTALLATION AND COMMISSIONING

WWS's engineers or chartered technicians required to carry out assembling, installation, commissioning, trial operation and training at site. The Employer is responsible for providing fullest support with two engineers, few technical officers, three skilled welders and ten unskilled persons to execute the erection, installation and commissioning works. The power supply must be present at the place of construction to ensure that the installation of all components within a train can be performed without interruption. The training of the skilled service personnel will be effected by the Contractor. Employer's Engineers will be present throughout the installation and commissioning. Any transport of our personnel and material in the country of the site have to be done and organized by the Employer.

The Employer has to provide normal hand tools needed to execute mechanical and electrical works. It is the Employer's obligation to provide temporary hoists, moving slides and other necessary equipment. Should special tools be needed, then WWS will make these available.

For the installation work it is essential to have all components supplied at the place of installation. The Employer shall give written notification of when installation can begin. The Employer is responsible that necessary building work is far enough advanced to permit installation to begin at the appointed time. It is indispensable that all conditions essential for the completion of the installation and commissioning works exist.

Alternative:

If, for reasons beyond the Contractor's influence (following listing only exemplary):

- consignment cannot be transported to or received at the site (powerhouse building not ready,...)
- installation and commissioning cannot begin within 60 (sixty) days from Contractor's notification that the consignment is ready for shipment
- installation and / or commissioning cannot be completed within 90 (ninety) days from a.m. notification

the following arrangement shall be made:

- the consignment is transported to the Port of discharge acc. to the Terms of Delivery
- the Employer has to arrange for storage at a warehouse / place of his choice at his own cost
- the balance amount for the equipment itself and installation and / or commissioning cost automatically becomes due after the period of 100 (hundred) days from the a.m. notification (i.e. cost not accrued are deducted from the Total Contract Value)

When the reasons for the unfavourable circumstances mentioned in above paragraph cease to apply, the Contractor shall as soon as possible fulfil his obligations according to the Contract; therefore a new time schedule shall be mutually agreed upon.

Any transport of our personnel and material in the country of the site has to be done and organized by the Employer.

The times and costs stated in the item "Installation and Commissioning" of the Contract are to be understood as guiding figures which can be reckoned with under favourable working conditions. Should the mentioned calculated periods not be kept due to unforeseen circumstances or due to poor and insufficient support given to WWS's supervisors, then the costs arising from the exceeded time will be calculated with rates mentioned under the paragraph „OPTIONAL COSTS“. In case of optional costs accrued these should be evidenced by protocols signed by the Employer and the Contractor (or his delegates).

CHAP. 13) CO- ORDINATION OF COMMISSIONING

The Employer has the responsibility to co-ordinate with the grid utility and make all the arrangements for commissioning. If there is any cost towards this the same has to be borne by the Employer. The Contractor will do only technical support like deputing expert for discussion if any.

CHAP. 14) OPTIONAL COSTS

In case of optional costs accrued the following day rates are valid for the costs of assembly, installation, training, commissioning and trial operation if proposed schedules for at site works are exceeded:

1 day rate for a mechanical engineer (for expatriate)	European Unit (EUR) 800,00
1 day rate for an electrical engineer (for expatriate)	European Unit (EUR) 900,00

The day rates are based on an actual working day of eight hours for five days a week, from Monday through Friday. For every hour overtime if the working period exceeds the eight hours working day a 50 % surcharge will be applied. For every hour overtime on Saturdays, Sundays and Holidays a 100 % surcharge will be applied.

The above mentioned rates include all labour costs. Travelling time is to be regarded as working time. Travelling costs for air tickets, train, bus or rent car and accommodation costs will be accounted for according to the actual expenses accrued supported by vouchers and documentary evidence.

CHAP. 15) OFFICIAL ACCEPTANCE

Immediately after termination of the mechanical installation, the consignment has to be accepted and taken over by the Employer by signing the PMCC.

Immediately after termination of the electrical installation, the consignment has to be accepted and taken over by the Employer by signing the PECC.

After PIO in connection with the take-over, a Certificate of Commissioning (CC) has to be drawn up. In case of minor defects, which cannot be amended on the occasion of supervision and which do not affect the efficiency, these have to be amended at a mutually agreed date between Contractor and Employer – without any unnecessary delay, but latest within the test period. In case of defects, which affect the efficiency, the Commissioning is deemed to be terminated only after amendment of these defects. All defects have to be noticed in the CC to agree on a mutual status. With the signature of the CC the Employer confirm to operate the equipment in the prescribed and cautious manner and accept some stop of operation to test the long-run operation and to adjust the high-tech equipment to a optimal operating status .

After the test run the FCC as to be drawn up, in which the parties confirm that the subject of the Contract satisfies the conditions in the Contract for take-over, and which states from which date the subject of the Contract is taken over and property thus passed to the Employer after the final payment of the contract price. The FCC shall be issued jointly by the Contractor and the Employer.

If the commissioning or agreed performance tests cannot be carried out within three months after signing the freight-documents, for reasons beyond the Contractor's influence, e.g. lack of water, grid problems, etc., the consignment has nevertheless to be approved and taken over by the Employer and a Provisional Certificate of Commissioning shall be drawn up and signed.

Both parties undertake the obligation to complete the performance tests within a three-month period from the date of the Provisional Certificate of Commissioning. In case the above unfavourable circumstances last for more than six months after signing the freight-documents or agreed performance tests cannot be completed for reasons outside one's control, the

CHAP. 16) DOCUMENTATION

Within eight weeks after opening of L/C and receipt of the Down Payment the contractor will submit outline drawings of the equipment to be furnished together with estimated weights, external forces, anchoring details and overall dimensions, to facilitate preparation of the structures into which the equipment is to be incorporated. The formwork and reinforcement plans must be prepared by the Employer.

As final documentation the contractor will submit operation manuals, spare part catalogues, workshop manuals, maintenance instructions, schematic wiring diagrams, general assembly drawings and sub-assembly drawings. The contractor shall furnish the employer with the usual erection and installation instructions and the relevant drawings.

In general the documentation is in English language. Some detailed descriptions might be written in German or other languages. Translations of documentation in other languages will be charged to the employer.

CHAP. 17) TRANSFER OF PERILS

The transfer of perils takes place according to the Delivery Terms stated in this contract. Upon arrival of the equipment at the port of discharge, the Employer takes all necessary measures to assure a perfect transport to the site or intermediate storing and subsequent transport of the equipment and particularly with regard to theft, damages caused, for example, by inclemency, humidity and/or fire etc. An insurance policy is taken out by the Employer covering delivered material, which is valued according to delivery note specifications. The Contractor will transmit to Employer before expedition, the values to be insured. The Employer must verify all material to ensure proper condition of delivered material and storage on site.

The passage of title will take place after payment of the contract price in full according to the terms of this contract.

CHAP. 18) RIGHT OF RETENTION

The Contractor is authorized to retain the whole plant or parts unless the Employer fulfilled his liabilities of the terms of payment agreed in this contract. The Employer must not deny his liabilities of payment in reference to the right of retention by the Contractor.

CHAP. 19) SAFETY PRECAUTION

The Employer shall provide free of charge for the contractor from the commencement of work on Site until taking over provide:

- (a) fencing, lighting and guarding of the Works; and
- (b) temporary roadways, footways, guards and fences which may be necessary for the accommodation protection and protection of owners and occupiers of adjacent property, the public and others.“

In case of any damage based on a shortage of safety equipment, the Employer has to compensate all costs of the Contractor.

CHAP. 20) WARRANTY

Art. 20.1) General Warranty

All goods indicated in the scope of supply by the contractor are warranted to be free from defects in workmanship and materials and in conformity with the technical specifications provided in the present contract. The warranty period is 12 months from the date of commissioning or 14 months from the date of readiness of shipment which ever occurs earlier.

The employer has to inspect immediately the delivery and workmanship effected on its completeness and to check if these are free from defects. Possible defects and reclamations etc. shall be reported immediately to the contractor by means of a written list naming the defects in detail or else claims of any kind shall be excluded.

This warranty includes all supplied mechanical parts of the turbine including all items of electrical & control systems. The warranty applies solely to the arising faults which evidently fall under the contractor's range of responsibility. The employer must explain in writing technically-wise and clearly the reasons for request the application of warranty.

The warranty is not applied when instructions specified in the operation and maintenance manuals are not respected. Excluded from compensation is wear, improper treatment, maintenance which is effected inadequately or not according to the operation and maintenance instructions. No warranty is given for defects caused by improper installation in the event that the installation has not been executed by the contractor as well as in case of misuse, excessive use, insufficient lubrication, defects in the foundation or disregard of the contractor's instructions, or if third parties have executed repairs or made additions to the products. The warranty will not apply for any circumstances outside one's control.

Any technical faults arising must be corrected by the contractor in the fastest possible means. The warranty and/or compensation of damages are effected either by repair or replacement of the defective equipment or grant a reasonable price reduction, whichever the contractor chooses to do. The warranty is limited to the repair or replacement of damaged equipment at the place where made, or to repair in place equipment proven defective and does not cover consumables such as light bulbs, fuses, oils, lubricants nor all costs incurred to uninstall and/or reinstall the defective equipment as well as cost for transport (if truck is reachable with a 40t-standard truck).

The contractor is discharged from executing any warranty obligations for the time where either the equipment has not been taken over with a signed provisional or final Certificate of Commissioning or the Contract Price has not been paid in full.

Art. 20.2) Efficiency and output guarantee

The efficiency values and the outputs, given in the technical specification are guaranteed according to the relevant IEC-Regulations 60041 of "Field acceptance test to determine the performance of hydraulic turbines, storage pumps and pumps- As per IEC-Regulations 60041, the employer and the contractor can agree mutually, if required, on one of the prescribed methods to measure the performance of the equipments. The tests must be carried out within the term of the guarantee and must be arranged and paid by the employer. In case of dispute, both parties have the right to refer to the applicable clauses of the relevant IEC-Regulations. A simplified measuring method can be arranged between the employer and the contractor. In case of doubt both parties have the right to consult the relevant IEC-regulations.

The performance of the equipment shall be measured by mutually agreeable methods. If performance tests are to be conducted by a third party the employer shall bear the cost for the tests. The third party shall be nominated by mutual agreement. In case the efficiency fall short, measured by the method accepted by both parties also after deduction of a measuring inaccuracy of 3 %, the contractor has the obligation and right , within the guarantee period, to carry out all required and possible modification to meet the agreed performance. Thereafter, and if the contractor is not able to rectify the problem within two months, the employer has the right to demand a penalty of 1 % of the contract price for each fall short percentage of the middle arithmetical efficiency of the guaranteed limit range of admission. However, if, due to generation losses, the Employer decides to do the rectification in a month suitable to the Employer, the Contractor has to arrange the rectification during that time. In this case maximum time permitted for rectification is limited to one and half years. The Employer has the right to refuse the turbine in case the percentage of efficiency fall short is more than 5 %. In case of refusal of turbine the Employer has the right to retain the turbine set until such time a new set is supplied/obtained. In case the efficiency test shows that the guaranteed efficiency is under-run, the costs for the test will be divided proportionately according to the percentage of deviation between the Employer and Contractor, whereby 5 % deviation are equal to 100 % of the expenses.

Art. 20.3) Cavitation guarantee

The runner will be guaranteed against deterioration due to cavitation for a period of 8000 hours of operation or two years after commissioning of the turbine, whichever ever occurs first, as long as the runner has been operated within the designed limits.

The cavitation pitting evaluation will be made in accordance with the relevant IEC-Regulations 60609 "Cavitation pitting evaluation in hydraulic turbines, storage pumps and pump-turbines".

Erosion or damage caused by solid particles or sand and corrosion caused by aggressive chemical substances in water or by galvanic or electrolytic action do not fall in the cavitation guarantee.

Under this guarantee the contractor undertakes to repair the resulting damages. All areas where the depth of pitting exceeds 3 mm shall be restored to their original contours by welding with stainless steel and grinding to the damage a smooth surface equal in finish to the adjacent undamaged areas. After repairs of cavitation the contractor agrees that the pitting guarantees are renewed from the date the employer agrees that repairs have satisfactorily been completed. In case of local cavitation damage caused or aggravated by any contour errors, the contractor shall make the modifications necessary in the turbine parts to prevent its reoccurrence.

CHAP. 21) PROVIDE SERVICE

The contractor guarantees that in the delivery are no execution or material defects and technical specification are in accordance with offer. The warranty period has a duration of 24 months from delivery. The service and maintenance warranty is 36 months. Any defects, complaints, etc., to be immediately known the contractor in writing by definite identification

The operating and maintenance instructions in the manuals are given to follow, to ensure that the warranty can be claimed. Excluded from the warranty is more natural wear and tear, improper handling and operation, inadequate or not performed in accordance with the maintenance requirements maintenance.

CHAP. 22) FIELD REPAIRS

For field repairs the employer will make the plant available at a mutually convenient time and will provide proper (reachable with a standard 40t-truck) access to the plant. The employer will also provide free of charge the use of cranes, hoists, station power and compressed air. All other items of equipment and materials required for the repairs shall be furnished by the contractor.

CHAP. 23) TEST RUN

The trial operation is spread over a period of 4 weeks after completion of commissioning with CC and handover of the plant to the employer. At the end of this period a FACC will be signed from both sides.

CHAP. 24) FORCE MAJEURE

If any Party should be prevented from fulfilling the whole contract or in parts for reasons of force majeure which may affect performance of his obligations he shall promptly notify the other party thereof. Such circumstance under force majeure means any circumstances beyond the control of the parties, including but not limited to:

- (a) war and other hostilities, (whether war be declared or not), invasion, act of foreign enemies, mobilisation, requisition or embargo;
- (b) ionising radiation or contamination by radio-activity from any nuclear fuel or from any nuclear waste from the combustion of nuclear fuel, radio-active toxic explosives, or other hazardous properties of any explosive nuclear assembly or nuclear components thereof;
- (c) rebellion, revolution, insurrection, military or usurped power and civil war;
- (d) riot, commotion or disorder, except where solely restricted to employees of the Contractor.

Art. 24.1) Effect of Force Majeure

Neither party shall be considered to be in default or in breach of his obligations under the Contract to the extent that performance of such obligation is prevented by any circumstances of Force Majeure which arise after the date of the confirmation order or the date when the Contract becomes effective, whichever is the earlier.

Art. 24.2) Performance to Continue

Upon the occurrence of any circumstances of Force Majeure the Contractor shall endeavour to continue to perform his obligations under the Contract so far as reasonable practicable. The Contractor shall notify the Employer of the steps he proposes to take including any reasonable alternative means for performance which is not prevented by Force Majeure. The Contractor shall not take any such steps unless directed so to do by the Employer

Art. 24.3) Additional Costs caused by Force Majeure

If the Contractor incurs additional costs in complying with the Employer's directions under the above mentioned Clause "Performance to continue", the amount thereof shall be certified by the Employer and added to the Contract Price.

When calculating the adjustment no account shall be taken of any increased cost which results from the Contractor's default or negligence.

Art. 24.4) Continuity of Payment

In case of force majeure in the sphere of the Employer the terms of payment are still to fulfil as agreed in this contract. The Employer cannot quit payment reference to force majeure.

In case of force majeure in the sphere of the Contractor the terms of payment are still to fulfil as agreed in this contract as far as the Contractor presents the necessary documents for the payment agreed in the terms of payment.

CHAP. 25) SPECIAL TERMS AND CONDITIONS

All instructions, approvals and notices to Contractor shall be issued or confirmed by the Employer in writing. Basically the communication is in English. Some detailed descriptions may be written in German.

The Employer reserves the right to visit the Contractor's factory and witness any examinations as far as it is possible in the workshop. The Contractor shall give due notice, approx. 7 days before the execution of any examination. During the inspection and/or the examination the Employer reserves the right to demand the immediate replacement of the faulty materials or the improvement of the goods according to the specification, in case the goods are not in accordance with the specifications stipulated herein. All cancellation or replacement expenses will be shouldered by the Contractor. The Contractor is liable to give any reasonable assistance, required by the Employer.

Should the Employer decide to cancel the project, all the costs and the expenses due to the cancellation shall be paid to the Contractor. The Contractor shall immediately stop the production upon receipt of the cancellation.

If the Employer decides to suspend the works or any part thereof for a certain period, the Contractor shall, on the written order of the Employer, suspend the progress of the works or any part thereof for such period, or periods, and in such manner which he considers necessary and shall, during such suspension, properly protect and secure the work so far as it is necessary. The extra costs born to the Contractor, by handling according to the Employer's instructions shall be shouldered and paid by the Employer.

Provided that the Contractor is entitled to recover any such extra cost, he shall give written notice of his intention to claim to the Employer, within fourteen days of the Employer's order. The Employer shall consider such an extra payment and/or extension of time to be made to the Contractor in respect of such claim and shall be fair and reasonable.

CHAP. 26) PLACE OF JURISDICTION

The place of jurisdiction is exclusively the international arbitration tribunal of vienna commodity market, AUSTRIA.

CHAP. 27) ARBITRATION

All disputes arising out of or in connection with the present contract shall be finally settled under the Rules of Arbitration of the International Chamber of Commerce by one or more arbitrators appointed in accordance with the said Rules.

CHAP. 28) LITIGATION

In the case where any litigation may arise, the Employer or the Contractor must clearly and explicitly explain the reason for litigation by registered mail. The other party must then formulate their answer with adapted solutions, no later than 15 days after receipt of litigation. Any dispute arising from the execution of an agreement shall be settled by discussion and agreement between the two parties.



CHAP. 29) LEGAL VENUE

If however the parties fail to agree all disputes arising out of or in connection with the present contract shall be finally settled under the Rules of Arbitration of the International Chamber of Commerce by one or more arbitrators appointed in accordance with said Rules and under the application of the Swiss laws. The provisions of the United Nations Convention on contracts for the international sale of goods ("The Vienna Convention") are hereby excluded from the contract. The legal venue of the arbitration will be at the Chamber of Commerce in Zurich, Switzerland. English language shall be applied for arbitration.

CHAP. 30) LIMITATION OF LIABILITY

The overall liability of the contractor is limited to the amount equivalent to 5% of the total contract..
The part with the biggest sound level is generator. WWS Wasserkraft take no liability for any amerce or indemnity as a consequence of noise.

CHAP. 31) LIMITATION FOR INDIRECT OR CONSEQUENTIAL DAMAGE

Neither party shall be liable to the other for any loss of profit, loss of use, loss of production, loss of contracts or for any other indirect or consequential damage that may be suffered by the other, except of wilful causation.

CHAP. 32) COMING INTO FORCE

The contract shall come into force after signature, receipt of down payment and opening and confirmation of L/C.

CHAP. 33) ASSISTANCE TO THE EMPLOYER

The Contractor has to provide the following services free of charge:

- Training of the staff which will be operating and maintaining the plant. Training will be in English.

- The Employer will have a representative on site during assembly and installation.

CHAP. 34) PRICES

Prices are expressed in EURO and are binding only after confirmation by the contractor

CHAP. 35) RETENTION OF TITLE

The delivered merchandise remain until complete payment property of the company WWS GmbH & CoKG. It is the extended retention of title.

CHAP. 36) VALIDITY OF THE OFFER

This offer is valid until 07.01.2017



CHAP. 37) DOCUMENT PRIORITY

If the documents in the contract contain mutually conflicting terms, the following documents shall apply in the following order:

- a) the contract document (Confirmation of Order, Purchase Agreement, ect.),
- b) General Conditions of Sale and Delivery of WWS Wasserkraft GmbH & Co KG, A-4120 Nefelden
- c) the tender/offer,
- d) given technical specifications
- e) acknowledged drawings
- f) The General Terms of Delivery of the Association of Austrian Machinery and Steel Construction Industries" and "The General Terms of Delivery of the Austrian Electrical and Electronics Industry"
- g) the invitation to tender with underlying documentation/the inquiry with underlying documentation

For issues not covered in the contract document, the "General Conditions of Sale and Delivery of the company WWS Wasserkraft GmbH & Co KG, A-4120 Neufelden" come in force.

If no contract document is to be drawn up, the Employer's written order shall in relation to the first paragraph be regarded as such a contract document, after the order has been accepted in writing by the Contractor.

Due to our longstanding experience in the design, construction and erection of equipment for hydro power plants we, WWS Wasserkraft we will assure you the best fulfillment of the contract and that you will be satisfied with our product and services.

Sincerely with best regards

Mr. Markus PEHERSTORFER
Sales Manager

WWS WASSERKRAFT GmbH & Co KG

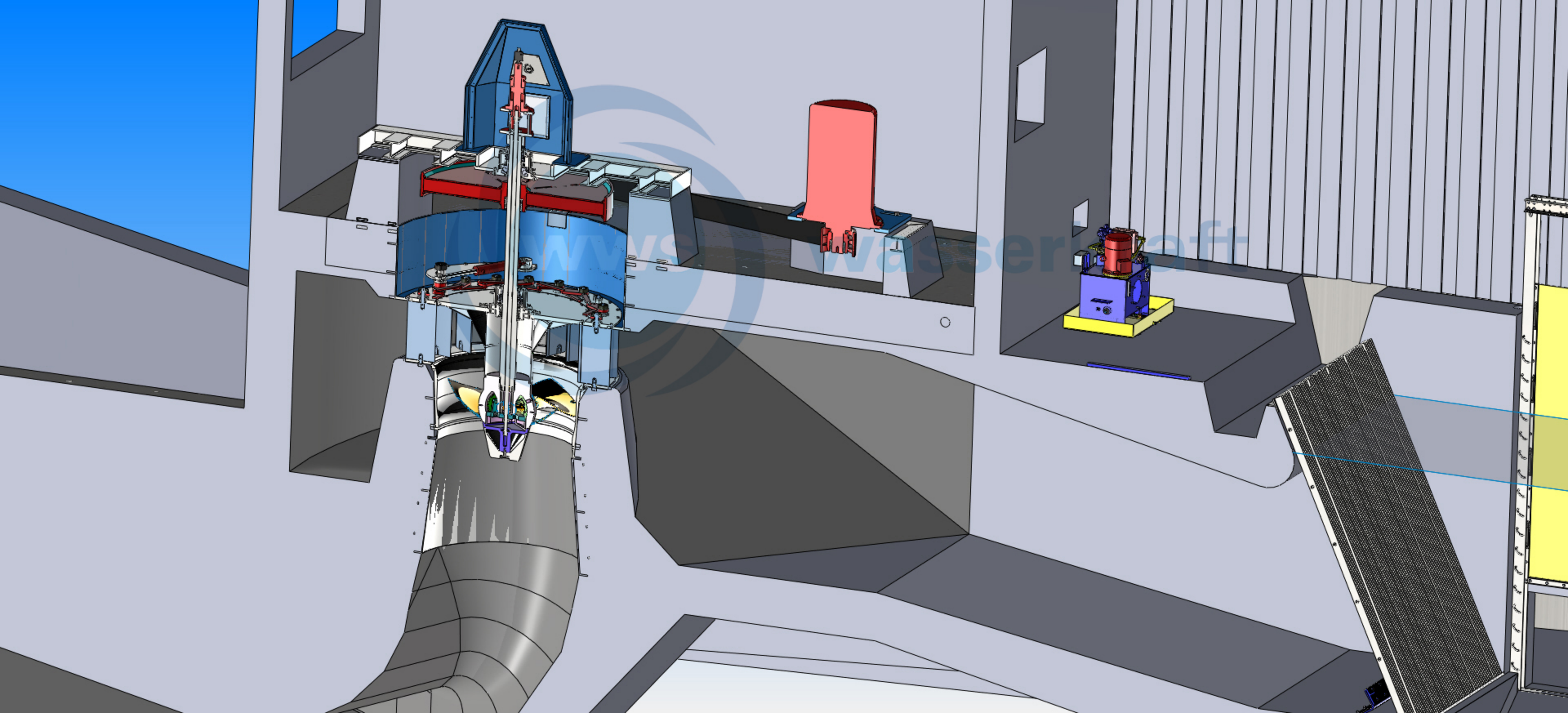

BUDGET PROPOSAL

A-4080 Paran Creek Projects Ossberger





Ossberger Hydro
72 Main street
Burlington, VT
USA

TEL: (438) 880-5655

Liam O. McRae
Bennington
liammcrae@bennington.edu

October 25th, 2016

ESTIMATE

Project A-4080 PARAN CREEK PROJECTS OSSBERGER

Hydroelectric equipment proposal for budgetary purposes, based on one Ossberger Turbine Set for each project,

DESIGN RATING FOR UNIT:

Option A - Lake Paran Dam – 1 unit SH5.153/9g

Gross head	HG	=	10.06 feet (5.81 m)
Net head	HN	=	18.11 feet (5.52 m)
Max. Flow	Qmax	=	48.57 cfs (1.38 m ³ /s)
Min. Flow	Qmin	=	4.8 cfs - 10% approx.
Turbine Output	PT	=	62 KW
Generator Output	PG	=	58 kW, 480V

Notes:

- A turbine rated for 60 cfs and with a turbine output of 76 kW would be approx. 10% more expensive
- A turbine rated for 67 cfs and with a turbine output of 85 kW would be approx. 20% more expensive

Option B - Firehouse Dam – 1 unit SH5.192/9g

Gross head	HG	=	12.04 feet (3.67 m)
Net head	HN	=	11.45 feet (3.49 m)
Max. Flow	Qmax	=	48.38 cfs (1.37 m ³ /s)
Min. Flow	Qmin	=	4.8 cfs - 10% approx.
Turbine Output	PT	=	38 KW
Generator Output	PG	=	36 kW, 480V

SCOPE OF SUPPLY

1. OSSBERGER Turbine (double cell, 1/3 – 2/3)
 - Crossflow 500mm diameter turbine, without cavitation through the complete operating range
 - Self-cleaning effect of the runner, no clogging
 - No axial thrust and therefore simple roller bearings are required
 - Bearings external to turbine casing
 - 2 guide vanes with maintenance-free bearings
 - 2 hydraulic cylinders



2. Base frame
3. HPU, cylinders and accessories
 - Connecting voltage: 480 V, 60 Hz
 - Model: S-2-DR/10
 - Brushless hollow-shaft tachometer
 - Two (2) rotating angle potentiometer
 - Two (2) lever arms with counter weights
 - Two (2) hydraulic cylinders
5. Transition Piece and draft tube
7. Speed increaser with Couplings (Gearbox)
 - a. Safety Factor min. 2,0
 - b. Air cooling system
 - c. Foundation blocks
9. Generator
 - a. Induction generator
 - b. Couplings
 - c. Nominal Voltage: 480V
 - d. Two (2) independent bearings
 - e. Temperature sensor PT 100 in stator winding, 2 pcs. per phase
 - f. Temperature sensor PT 100 in bearing shield, 1 pcs. per bearing
 - g. Foundation blocks
10. Switchgear and control

PRELIMINARY LAYOUT

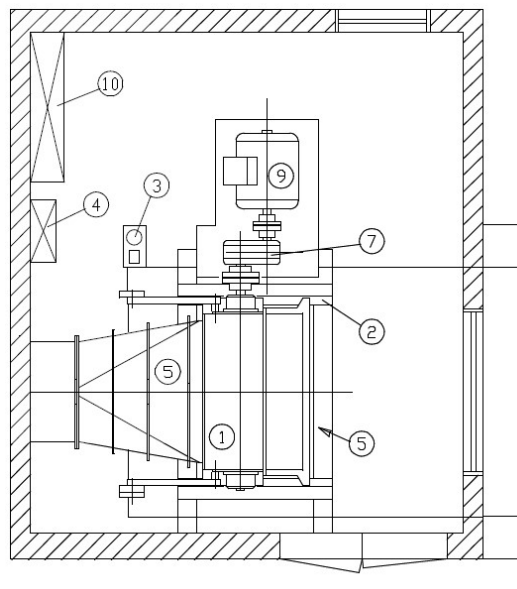



EFFICIENCY

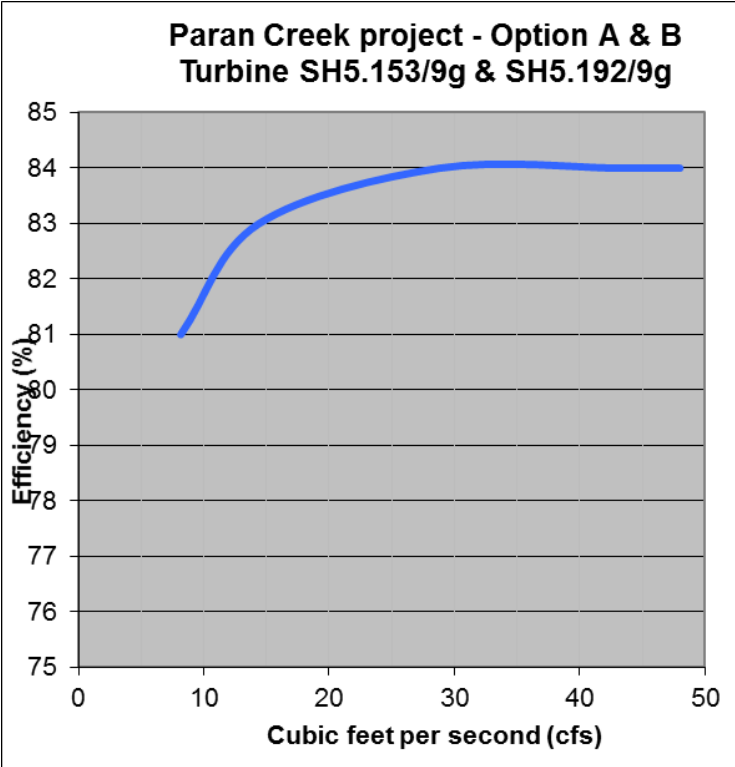

Note:

- Turbine can operate at least as low as 10% of maximum flow

PRICE ESTIMATE

	Price (EURO)
Option A - Lake Paran Dam – Items 1,2,3,5,7,9	140,000
Option B - Firehouse Dam – Items 1,2,3,5,7,9	140,000

Ossberger Hydro can provide the complete water-to-wire including the Switchgear & Control (Item 10). The cost for these components can vary depending on the required options between 40,000 to 70,000 USD (to be confirmed). Power transformer can also be added (price to be confirmed).



OTHERS

- a. Packing and Crating for sea freight included
- b. Freight and Insurance included
- c. Delivery as per DDU terms

As part of this budget offer we have included the following additional information in the form of attachments:

- a. Ossberger turbine brochure
- b. Ossberger turbine description

We hope this budget price estimate meets your expectations. For additional questions please do not hesitate to contact us.

Loïc Pétilion, Eng.
Project Director
OSSBERGER HYDRO

Tel: 438-880-5655
Email : loic.petillon@ossberger.ca



The original
OSSBERGER® Crossflow Turbine



History

The history of the original OSSBERGER® Crossflow Turbine started with an intellectual exchange between two highly innovative geniuses: the Australian inventor Anthony Mitchell and the German entrepreneur Fritz Ossberger. The latter was granted an Imperial Patent for his “free-jet turbine” of the year 1922.

After numerous refinements, the “cross-flow turbine” went into production in 1933. Fritz Ossberger also obtained a further Imperial Patent for this machine.

These days, the "Ossberger turbine" is a benchmark for excellence in the technology of small hydro power generation. With its history of more than 100 years Ossberger GmbH + Co of Weissenburg is your reliable manufacturer of the original - often imitated, but never matched. Over 10,000 units are installed in more than 100 countries worldwide.



Original OSSBERGER® Crossflow Turbines

Original OSSBERGER® Crossflow Turbines are optimal within a power range between some few kilowatts and a present maximum of 5 megawatts per machine. They are tolerant of debris in the water and adjust perfectly to accept varying flows; that is why they are extremely well suited for use in **run-of-river locations**. Smooth, quiet operation can be expected from almost zero up to full load. They have proven themselves to be reliable in the field at thousands of locations, even under the most severe conditions, over many decades.

Thanks to their cavitation-free operation even at minimal flows the original Ossberger® Crossflow Turbines are ideal for **stand-alone units**. They robustly meet the requirements of the constantly varying demands of energy consumers.

Original OSSBERGER® Crossflow Turbines are entirely steel-welded and built from standardized individual components. This modular system facilitates low-cost manufacture whilst meeting the individual design criteria to suit any specific project. Thus, a tailor-made plant is configured precisely according to individual site requirements.



Operating principle

The original OSSBERGER® Crossflow Turbine is a free stream turbine with radial and partial admission which - depending on the head - can also be combined with a draft tube. Due to its specific speed it is classified as a slow speed turbine. The water jet enters the cylindrical rotor through the one or two guide vanes, passing through it entirely. The advantage of this flow pattern is that any ingress by leaves, grass, wet snow, etc. is flushed out again by the selfcleaning effect of the rotor.

Where restricted by seasonal water availability, the original OSSBERGER® Crossflow Turbine automatically adjusts with two guide vanes in a relationship of one third to two thirds. The small guide vane alone operates with water flows admitted of about 5% entering while maintaining the efficiency guarantee level at about 17% of the design flow. The big cell takes over at 33% of the flow, and both cells operate together from 67% up to full load - with a constant high level of efficiency.

This is how original OSSBERGER® Crossflow Turbines can operate most efficiently even at varying flows.

Efficiency

The average overall efficiency of original OSSBERGER® Crossflow Turbines with a draft tube is calculated at 84% over the entire operating range. Turbines without a draft tube show efficiencies of up to 87%.

The graph on the right clearly illustrates the superiority of the original OSSBERGER® Crossflow Turbine in the partial load range. Turbines with high peak efficiency, but poor partial load behaviour, produce significantly less annual power output in run-of-river power stations with varying flow than turbines with a flat efficiency curve.

Most running waters offer high flow rates only on a few days per year. With its two-cells construction, the original OSSBERGER® Crossflow Turbine still exploits water quantities far too small for a Francis-Turbine, increasing thus considerably its annual performance (see graph below).

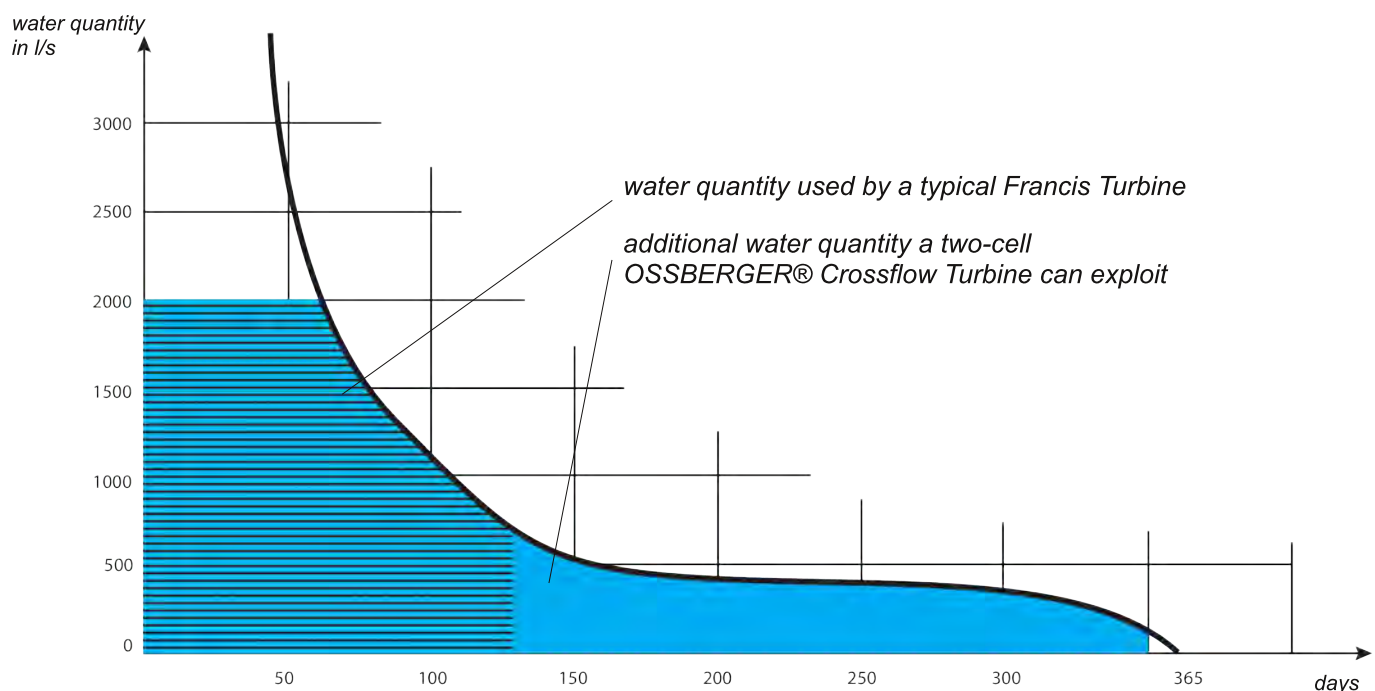
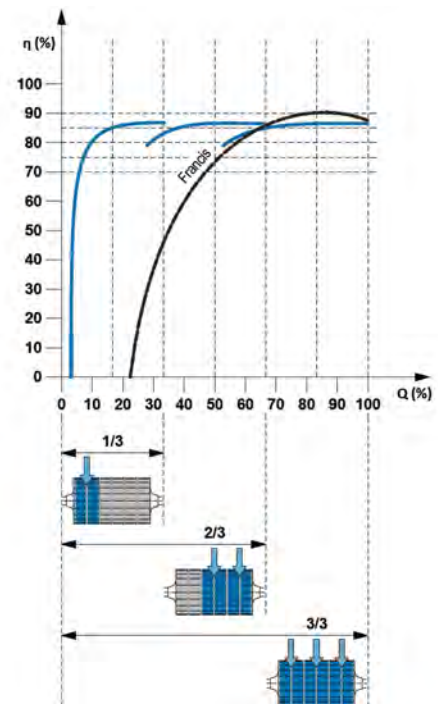

Applications

Small scale OSSBERGER® hydro stations not only enjoy the highest reputation worldwide for their supreme technical standards but also for their remarkable range of operating flows. At **run-of-the-river sites**, our turbines are suited to all types of operation.

The turbines can also be used for **water management-related tasks**, such as discharge and residual water flow regulation. According to local requirements, stored water can be discharged through the plant, e.g. for irrigation purposes, and at the same time used for energy production – while the turbine controls the flow rate.

Typical applications for service water:

- Discharge sections of sewage plants
- Drinking water supply
- Dosing/residual water
- Irrigation systems
- Bottom outlets of dams
- Canal locks
- Cooling systems of conventional power stations
- Water balance and flood protection
- Seawater desalination plants etc.

In **stand-alone operation** (“offgrid”) the synchronous generator driven by the original OSSBERGER® Crossflow Turbine responds to the actual demand, always automatically producing as much energy as needed by the connecting and disconnecting consumers. The permanently varying energy requirement means a challenge to a power station.

Original OSSBERGER® Crossflow Turbines are ideal for stand-alone operation, with an unlimited working range from no to full load; additionally, due to their refined design, they are free from vibrations or cavitation. The automatic speed control provides constant frequency and tension. Black start conditions are guaranteed by a manual pump installed on the turbine governor's hydraulics rendering the use of a battery system unnecessary.

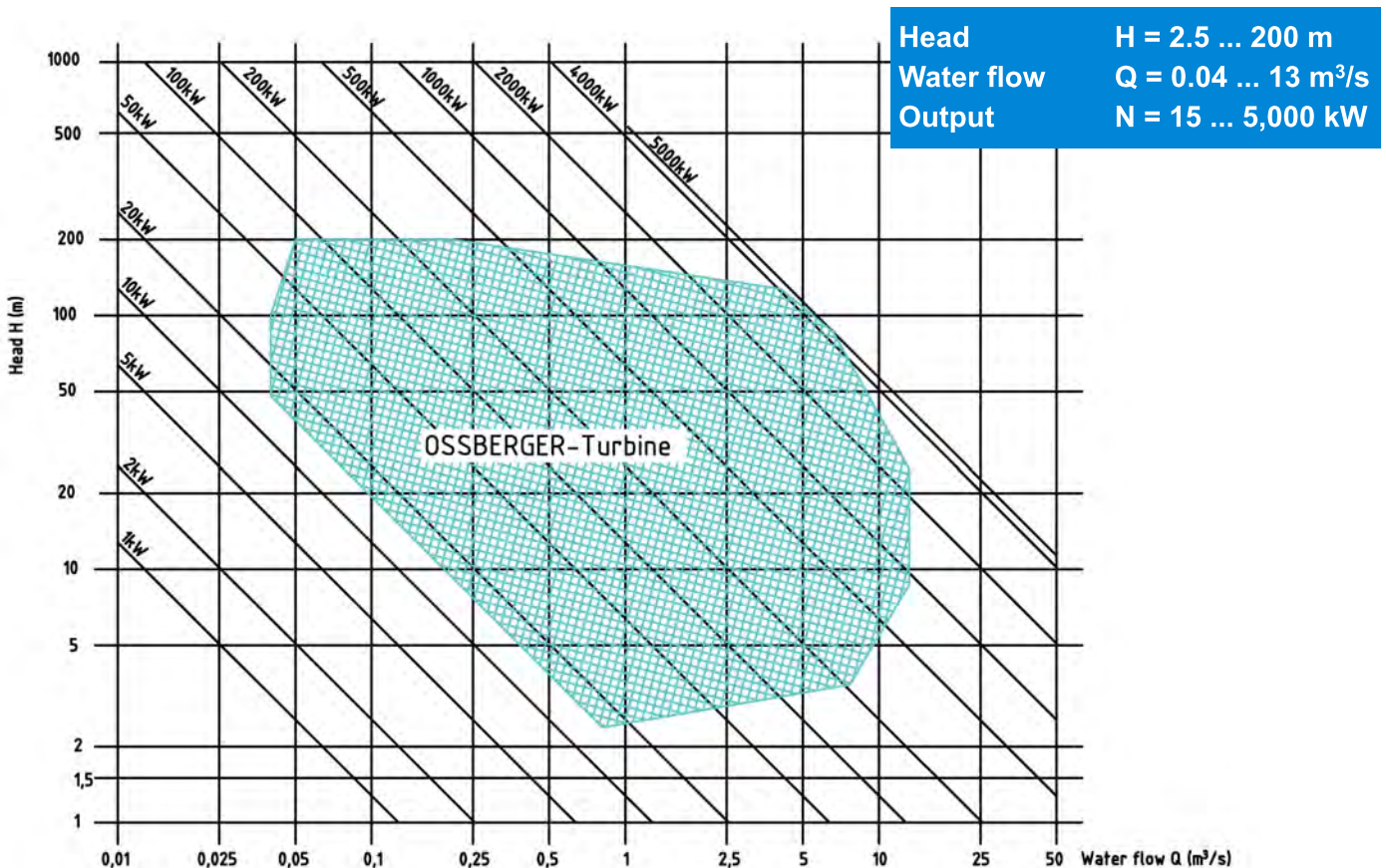

Advantages of the original OSSBERGER® Crossflow Turbines

Technical superiority:

- The system allows for the use of widely varying flows at constantly high efficiency levels
- Utilizing the OSSBERGER draft tube turbine concept, no head is lost, from upstream to the downstream water level
- Compared with imitation crossflow turbines, the machine is particularly outstanding in its operating and regulating behaviour as well as efficiency characteristics
- No axial thrust, consequently simple low-maintenance bearings
- Proverbial simplicity (only two or three movable elements)
- Drop weights are incorporated for reliable emergency shut down, so no DC current supply is required
- Simple adjustable shaft seals (hemp tallow)

Cost savings:

- No demanding civil works construction; only flat, straight and even structural surfaces are required
- Quick and easy installation
- Minimal maintenance requirements: Periodic greasing and annual grease changes, no need for special tools
- Good accessibility of the machinery from all sides
- No forced standstill due to an obstructed runner (because of the self-cleaning effect of the OSSBERGER runner)
- Higher profits thanks to the use of lowest flows
- The hermetically closing guide vanes are sufficient for shut down of the unit, so no automatic valve is needed in front of the turbine

Ecologic benefit:

- Cleansing effect of the water

Ossberger quality:

- Guide vanes are calibrated, specially fitted and hydraulically balanced, assuring vibration free operation, outside cavitation limits, at high efficiency levels
- Industrial components for a long service life, no electronic elements of short lifetime
- Maintenance-free bearings of the guide vanes
- Best production quality "Made in Germany"



The components of the original OSSBERGER® Crossflow Turbine

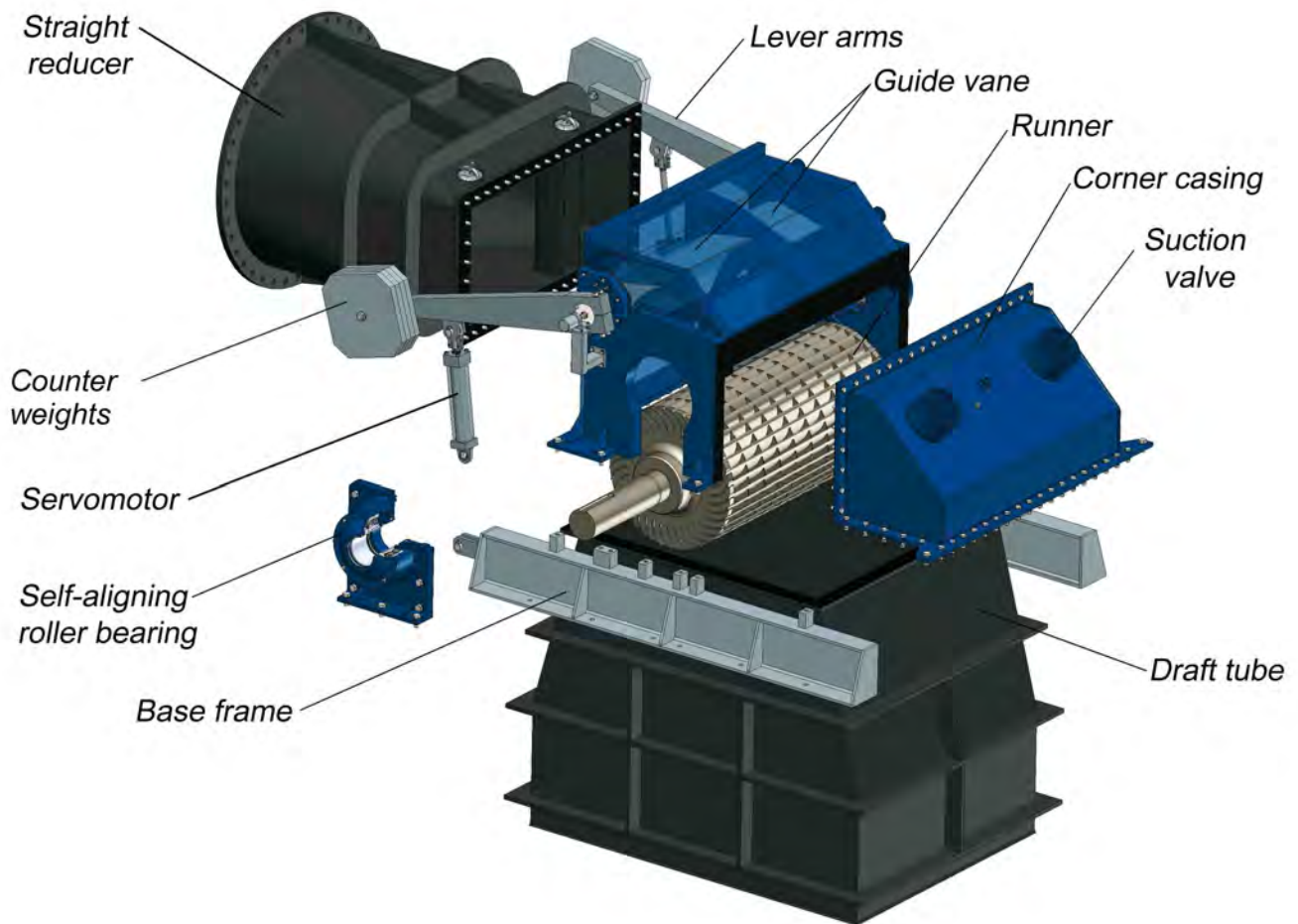

Casing

The casing of the original OSSBERGER® Crossflow Turbine is entirely steel-welded, unbeatably robust, both impact and frost resistant. The removable corner casing enables an easy access to the runner.

Bearings

The original OSSBERGER® Crossflow Turbine is equipped with standardized spherical roller bearing inserts for robust durability. The bearing casings and the bearing inserts form a unit that allows the radial dismounting of the runner without removing the bearing casings from the runner shaft.

In addition, this patented bearing construction has the advantage that no grease can contaminate the water flow. At the same time, the rotor is centered within the turbine casing.

Maintenance-free sealing elements complete this superior technical solution. Apart from an annual grease change, the bearing does not require any maintenance.

Guide vanes

In the subdivided original OSSBERGER® Crossflow Turbine, the admission of feed water is controlled by two balanced profiled guide vanes which divide the water flow, direct it and allow it to enter the rotor smoothly. Both guide vanes are fitted precisely into the turbine casing keeping the amount of leakage so low that in the case of small heads the guide vanes can also serve as shut-off devices. Both guide vanes can be adjusted separately via lever arms to which an automatic or manual control is connected. With the subdivided guide vanes a flat efficiency curve is achieved. They can easily be dismounted in radial direction; no special tools are needed for this purpose. Forces are absorbed by maintenance-free friction bearings, running on special steel surfaces.

Base frame

The stable base frame mounting turbine and foundation allows for a quick, simple and safe installation.

Runner

The heart of the turbine is the drum-shaped rotor. It is equipped with blades made of bright-rolled profiled steel manufactured by our well-proven procedure. On both sides, end discs are adapted and welded using a special technique. Depending on its size, the rotor has up to 37 blades supported by several intermediate discs. This makes the rotor extremely rigid, stiffening it in a way that no vibrations can occur. The rotors are carefully balanced prior to final assembly. A simple readjustable gland packing arrangement with tallow cord seals the shaft.

Draft tube and suction valve

The original OSSBERGER® Crossflow Turbine can be used as a free jet as well as a draft tube turbine. The draft tube allows for the lossless use of the full head and is generally installed in hydro plants with a head of less than 40 meters.

By means of an adjustable air inlet valve regulating the vacuum in the turbine casing for the optimum use of the energy potential, the suction water column is controllable. In this way, even heads of as little as 2.5 m can be fully exploited by OSSBERGER draft tube turbines.

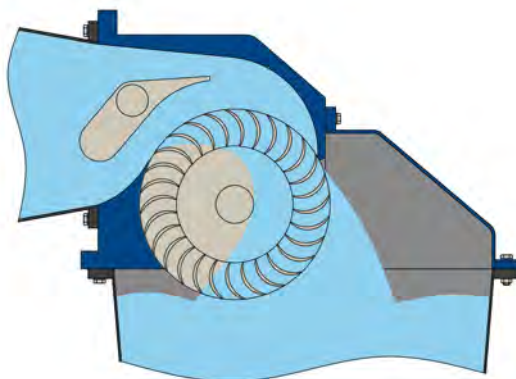

horizontal inflow

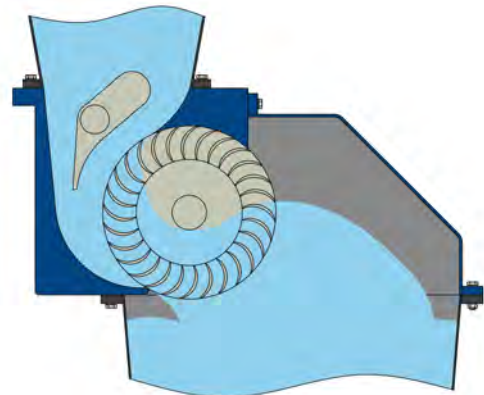

vertical inflow

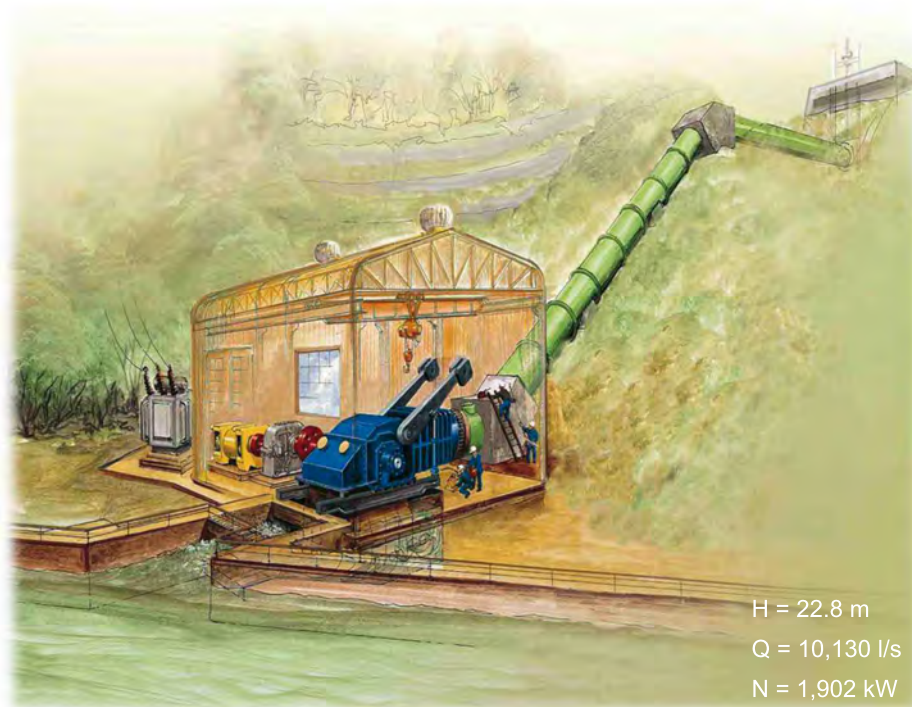

Materials

Various component materials are required for the different uses and applications of turbines. Ossberger selects materials, according to the specific demands (mechanical or chemical stress, drinking water, salt water, etc.). For this purpose, the wear of individual elements is considered to optimize the operating costs; another benefit of our great experience.

The following materials are used in production:

Carbon steel
Stainless steel V4A
Wear resistant steel (e.g. Hardox)
Superduplex



The Ossberger product range

- Original OSSBERGER® Crossflow Turbines (from 15 kW up to 5 MW)
- Kaplan turbines (from 20 kW up to 2 MW)
- Trash rack cleaning systems, also for big hydro plants
- Automation OTmation

For a detailed offer and information on our further products, please do not hesitate to contact us.



OSSBERGER GmbH + Co
Otto-Rieder-Straße 7
91781 Weißenburg/Germany
+49 (0) 91 41 / 9 77-0
info@ossberger.de
www.ossberger.de



The Ossberger® Turbine

OSSBERGER Turbines are basically individually tailored to the operating conditions to be encountered on a barrage (head/water flow)

Operating range:	
Heads:	$H = 2,5 \dots 200 \text{ m}$
Water flows:	$Q = 0,04 \dots 13 \text{ m}^3/\text{s}$
Power:	$N = 15 \dots 3\,000 \text{ kW}$

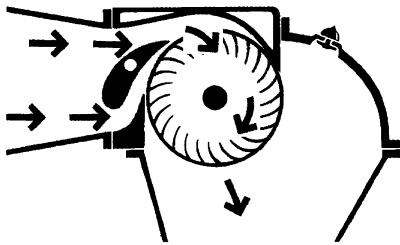

Picture 1 Inflow horizontal

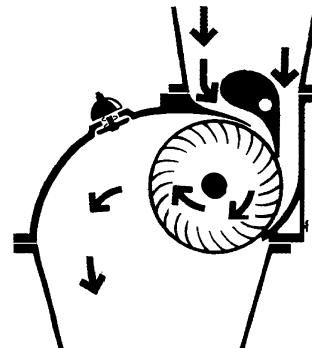

Picture 2 Inflow vertical

Flow Pattern in OSSBERGER Cross-Flow Turbines

Principle

The OSSBERGER turbine is a radial and partial admission free stream turbine. From its specific speed it is classified as a slow speed turbine. The guide vanes impart a rectangular cross-section to the water jet. It flows through the blade ring of the cylindrical rotor, first from the outside inward, then after passing through the inside of the rotor from the inside outward.

This flow pattern also has the advantage in practice that leaves, grass and wet snow, which when the water enters are pressed between the rotor vanes, are flushed out again by the emerging water – assisted by centrifugal force – after half a revolution of the rotor. Thus the self-cleaning rotor never becomes clogged.

Where the water supply requires, the OSSBERGER is built as a multi-cell turbine. The normal division in this case is 1:2. The small cell utilises small and the big cell medium water flow. With this breakdown, any water flow from 1/6 to

1/1 admission is processed with optimum efficiency. This explains why OSSBERGER turbines utilise greatly fluctuating water supplies with particular efficiency.

Efficiency

The mean overall efficiency of OSSBERGER turbines is calculated at 80% for small power outputs over the entire operating range. These efficiencies are normally exceeded. Efficiencies of up to 86% are measured in the case of medium-sized and bigger units.

Figure 3 clearly illustrates the superiority of the OSSBERGER turbine in the partial load range. Small rivers and water courses often have reduced water flow for several months of the year. Whether or not power can be generated during that time depends on the efficiency characteristics of the particular turbine. Turbines

with a high peak efficiency, but a poor partial load behaviour, produce less annual power output in run-of-river power stations with a fluctuating water supply than turbines with a flat efficiency curve.

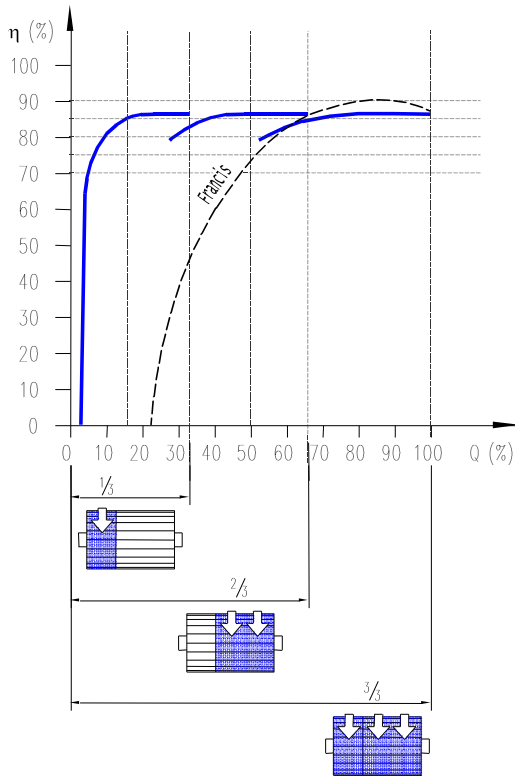

Picture 3 Efficiency characteristic of an OSSBERGER turbine developed from the 3 efficiency curves of a 1 : 2 division compared with the Francis turbine.

Guide Vanes

In the subdivided OSSBERGER turbine the admission of feed water is controlled by two balanced profiled guide vanes which divide the water flow, direct it and allow it to enter the rotor smoothly independent of the opening width. Both guide vanes are fitted very precisely into the turbine casing. They keep the amount of leakage so low that in the case of small heads the guide vanes may serve as shut-off devices. Main slide valves between the pressure pipe and the turbine can then be dispensed with. Both guide vanes can be adjusted independently of one another via regulating levers to which the automatic or manual control is connected. The guide vane bearings are maintenance-free.

Casing

The casing of the OSSBERGER turbine is entirely made of steel, exceedingly robust, lighter than a grey cast iron, impact and frost resistant.

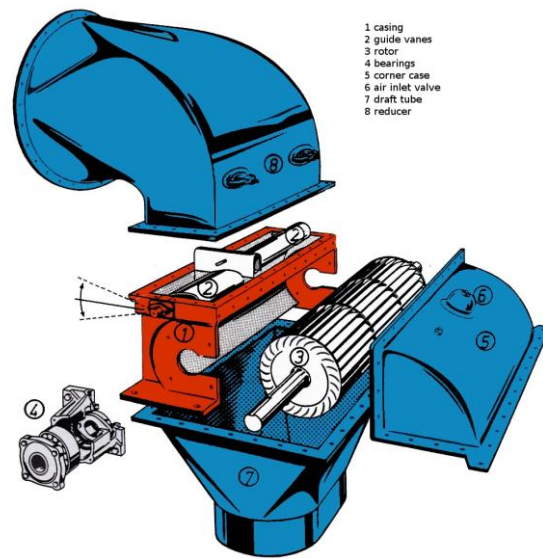

Picture 4 Design of a two-cell OSSBERGER Turbine

Rotor

The heart of the turbine is the rotor. It is equipped with blades, manufactured of a bright-rolled profiled steel by a well-proven procedure, adapted to end disks on both sides and welded by a special procedure.

The rotor has up to 37 blades depending on the size. The linear curved blades produce only limited axial thrust so that the multi-collar thrust bearings with all their disadvantages are eliminated. In the case of wider rotors the blades have multiple interposed support plates. The rotors are carefully balanced prior to final assembly.

Bearings

The main bearings of OSSBERGER turbines are fitted with standardised spherical roller bearing inserts. Roller bearings have undeniable advantages in water turbines provided that the design of the bearing housing prevents any leakage or condensation occurring. This is the essential feature of the patented bearing construction in OSSBERGER turbines. At the same time the rotor is centred in relation to the turbine casing. Maintenance-free sealing elements complete this superior technical solution. Apart from an annual grease change the bearing does not require any maintenance.

Draft Tube

In its design principle, the OSSBERGER turbine is a free-stream turbine. In the medium to low head range a draft tube is essential however. It serves reconcile the need for high-water safety and lossfree utilisation of the full head. On a free-stream turbine with a wide operating range therefore the suction water column must be controllable if the turbine is to be constructed as a draft tube turbine. This is achieved by means of an adjustable air inlet valve which regulates the vacuum in the turbine casing. In this way even heads of as little as 2 m can be fully utilised by OSSBERGER draft tube turbines.

Operating characteristics

Due to its very design, cavitation does not occur in an OSSBERGER turbine. The turbine is always arranged above the tailwater level. So essential savings are obtained with regard to the civil costs. The machine can also be run within the whole range of admission without restrictions.

Due to the relatively low run-away speed of OSSBERGER Turbines serial generators can be used.

"Keep it simple" was the watchword when developing the OSSBERGER turbine. It is designed for continuous operation over a period of decades and can be run without any special maintenance equipment. It is frequently installed and commissioned by non-experts – especially in third world countries.

Low-Cost Design Formula

Great environmental awareness means striving to harness natural forces without wasting materials or harming the environment, e.g. generating electricity from recycled energy sources. The use of hydro-electric plants is limited however by one major factor: the high investment costs associated with the design and planning and the construction of machinery and hydraulic engineering.

Consultant engineers and turbine manufacturers have therefore attempted to reduce the overall costs by standardising water turbines. This possible course with large turbines leads, however, to problems in the design of small water turbines connected with the water flow and annual range of fluctuation in the water supply.

OSSBERGER turbines are built from standardised components which can be configured according to requirements, that is according to the water flow and head of the particular barrage, to produce a tailor-made plant. This modular system facilitates low-cost manufacture whilst still designing the functions to suit the particular project.

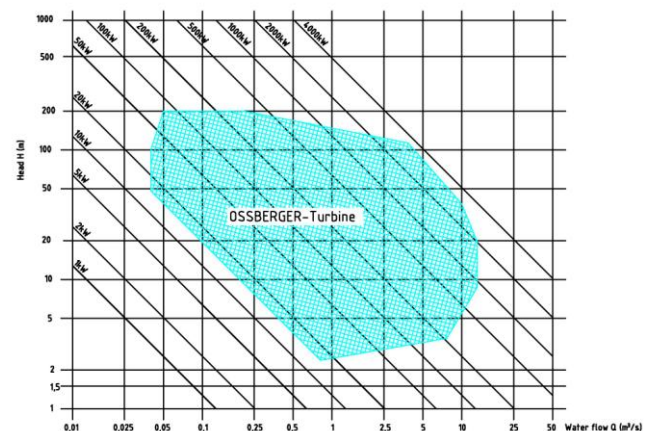

Picture 5: Range of use



OSSBERGER GmbH + Co
Otto-Rieder-Strasse 7
91781 Weissenburg/Bayern
Fon +49 (0) 91 41 / 9 77 -0
Fax +49 (0) 91 41 / 9 77 -20
e-mail: info@ossberger.de
www.ossberger.de



Bill Scully <wfscully@gmail.com>

Re: A-4080 - Paran Creek Projects - Ossberger

jacques.gauthier@ossbergerhydro.com <jacques.gauthier@ossbergerhydro.com>

Tue, Nov 8, 2016 at 5:08 PM

To: Liam McRae <liammcrae@bennington.edu>

Cc: loic.petillon@ossberger.ca, Bill Scully <wfscully@gmail.com>

Hi Mr. McRae,

Here as requested efficiencies Ossberger cross flow turbine !!

100% turbine flow = 83,9% efficiency,
90% turbine flow = 83,9% efficiency,
80% turbine flow = 84% efficiency,
70% turbine flow = 84% efficiency,
60% turbine flow = 84% efficiency,
50% turbine flow = 83,8% efficiency,
40% turbine flow = 83,5% efficiency,
30% turbine flow = 83% efficiency,
20% turbine flow = 81,6% efficiency,
10% turbine flow = 60% efficiency,

Best regards,
Jacques Gauthier

OSSBERGER HYDRO
USA & CANADA

Cell: [438-880-5655](tel:438-880-5655)

Email : loic.petillon@ossberger.ca

www.ossbergerhydro.com

----- Original Message -----

Subject: Re: A-4080 - Paran Creek Projects - Ossberger

From: Liam McRae <liammcrae@bennington.edu>

[Quoted text hidden]

SUMMARY OF SUPPLY QUOTE AND PROPOSED TERMS

Letter of Intent for Purchase of Equipment

Lake Paran Dam

October 27, 2016

Description This term sheet captures summary terms and conditions of an agreement for the sale and purchase of hydro electric generation equipment between Natel Energy, Inc. (“Natel”) and Scully Consulting Services (“Purchaser”), jointly the Parties.

Transaction Background This material is in response to an RFP by Scully Consulting Services dated September 29, 2016. Site characteristics were provided therein. Natel Energy has not directly assessed the site.

Project The Lake Paran Dam, North Bennington Vermont, US

Rated Head 19.0625 ft

Flow Data See flow duration curve in Appendix A.

Expected Installed Capacity

186 Energy Annual MWh	76 Max Power kW	28% Plant Factor	1 HydroEngine 1xPJ-7A-L	5.8 Design Head Meters	2.1 Max Flow CMS
-----------------------	-----------------	------------------	-------------------------	------------------------	------------------

Calculated 7 days ago by jin@natelenergy.com

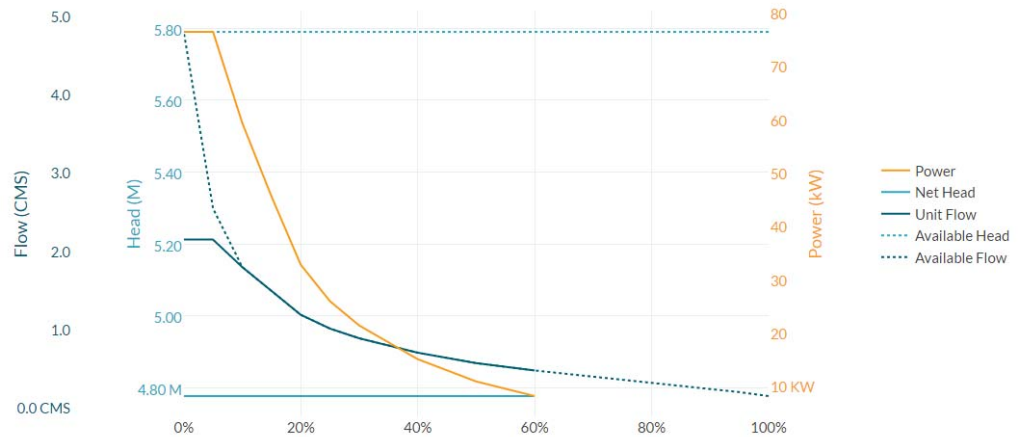

Natel Equipment Specified The following Natel SLH Systems will be supplied to the Purchaser.

SLH System	# Units	Budgetary Cost Estimate
1xFJ-7A	1	\$180,000

Unless otherwise noted herein, the following will be provided with each SLH System:

- SLH (housing + cassette + penstock adaptor)
- Power Takeoff (generator + gearbox + alignment frame)
- Controls (SCADA compliant)

Estimated Delivery Date Natel’s standard delivery window is 9 months from order for the first unit. Purchaser and Natel will keep each other apprised of the stage of the Project and update the delivery date as necessary. Until such time as a binding contract is signed, the Estimated Delivery Date is subject to change by either Party, without limitation.

Services Included The following are included with the purchase of the SLH system:

- Input on SLH integration into site design.
- Interface with and consultation with customer EPC.

Technical Advisory Support at the Project Site during installation, Startup and Commissioning for 2 technicians full-time for 2 weeks.

Additional Services On site installation assistance beyond the commissioning activities will be provided at \$150 per hour.

Monitoring & Maintenance Service Purchaser will enter into a contract for either:

- Operations and Maintenance Service including all scheduled maintenance activities and parts and warranty-related unscheduled maintenance and parts for the period of 20 years, or
- Condition Monitoring and Reporting Service for the period of 20 years,
- at a rate to be determined based on timing of order and number of customer projects in the region

Warranty Natel provides a 2 year warranty on the SLH turbine

Expenses The parties will each bear their own legal and other expenses with respect to the transaction contemplated herein.

The preceding is an indicative summary of the terms and conditions for the proposed transaction between the Parties. This term sheet does not constitute an agreement, offer, nor a commitment to engage in the transaction described herein. In addition, the terms herein are not, nor meant to be, all-inclusive of the terms and conditions that the parties will require if they were to enter into a final and binding commitment. Any such final agreement shall be binding only upon execution of a fully negotiated and duly executed agreement. The Parties reserve the right, pending such final negotiation and execution, to modify the terms or abandon entirely the transaction proposed herein, without any liability to it. The Parties acknowledge that these materials are confidential and proprietary and mutually undertake not to disclose or provide these materials, or any information relating to the proposed transaction, without the consent of the Party providing the information, to any third parties, other than those authorized employees and advisors of recipient who need to know such information for the purposes of evaluating the proposed transaction.

Appendix A: RFP Data Request Items:

System efficiency curve:

186 Annual MWh Energy	76 kW Max Power	28% Plant Factor	1 HydroEngine 1xHJ-7A-L	5.8 Meters Design Head	2.1 CMS Max Flow
-----------------------------	-----------------------	---------------------	-------------------------------	------------------------------	------------------------

Calculated 7 days ago by jin@natelenergy.com

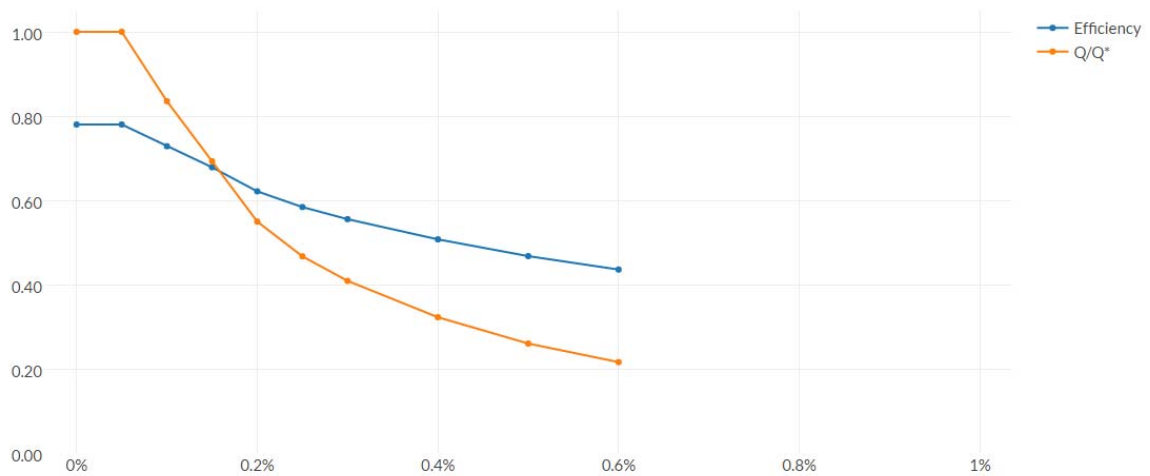

Exceedance %	Flow (CMS)	Power (kW)
100%	0.133	
95%	0.184	
90%	0.223	
80%	0.3	
75%	0.34	
70%	0.383	
60%	0.46	8.005
50%	0.554	10.743
40%	0.687	14.926
30%	0.871	21.235
25%	0.995	25.791
20%	1.171	32.632
15%	1.476	45.424
10%	1.78	59.221
5%	2.53	76.294
0%	4.784	76.294

Basic configuration drawings:

Our configuration suggestion for Lake Paran Dam parallels that in the RFP with likely improved civil layout at the powerhouse. The hydroEngine itself does not need submergence below tailwater, so the powerhouse itself needs less excavation. There is no draft tube, but instead the hydroEngine sites on a cement box with discharge directly down.

The channel back to the downstream can also be simple concrete culvert to the downstream but does not need extra submergence and attendant excavation for a relatively inexpensive discharge downstream of the dam. The path back to the downstream river can be either a simple channel or large diameter pipe and it is all at atmospheric pressure. A rough representation is presented here with zoomed in detail on the powerhouse following:

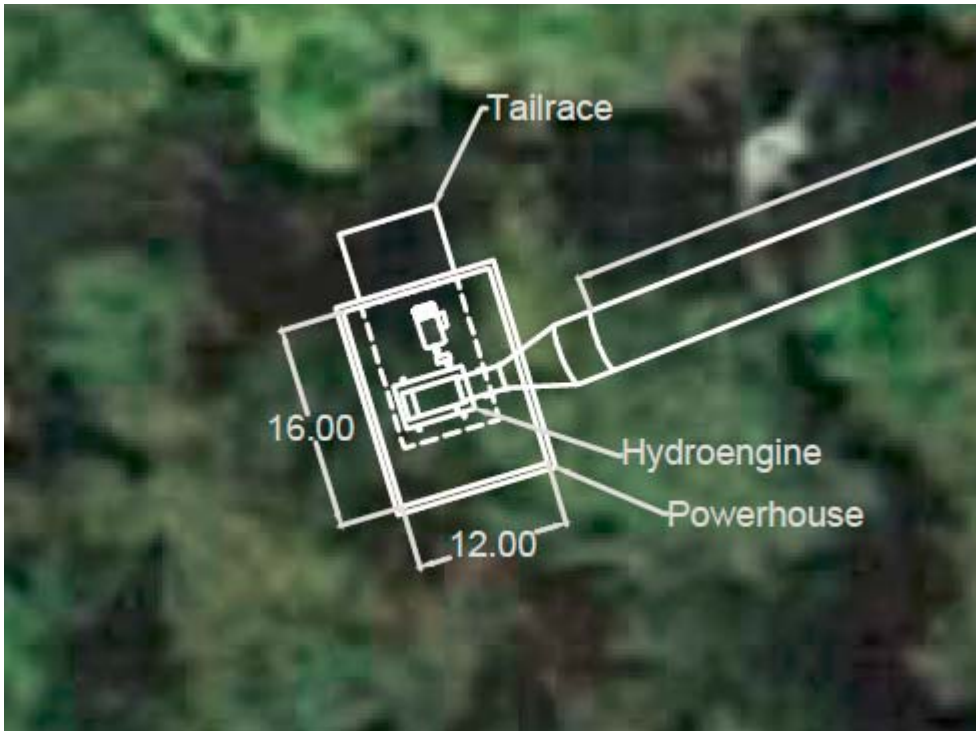

**List clearly all equipment included in quotation.**

Please see the standard term sheet above.

Services:

- List of all services included in quotation.
Please see the standard term sheet above.
- Information on manufacturer installation services required beyond scope of quotation.
Please see the standard term sheet above.

Assurances

- Provide any warranty and extended warranty information.
Please see the standard term sheet above.
- Detail any production guarantees.
Please see the standard term sheet above.
- All prices quoted must be good for 18 months.
Please see the standard term sheet above.

APPENDIX B: Flow Duration Curve at Lake Paran Dam

Name: Lake Paran Dam
 Location: North Bennington, Vermont, USA
 Basin: Basin 1 – Batten Kill, Walloomsac, Hoosic River Basin

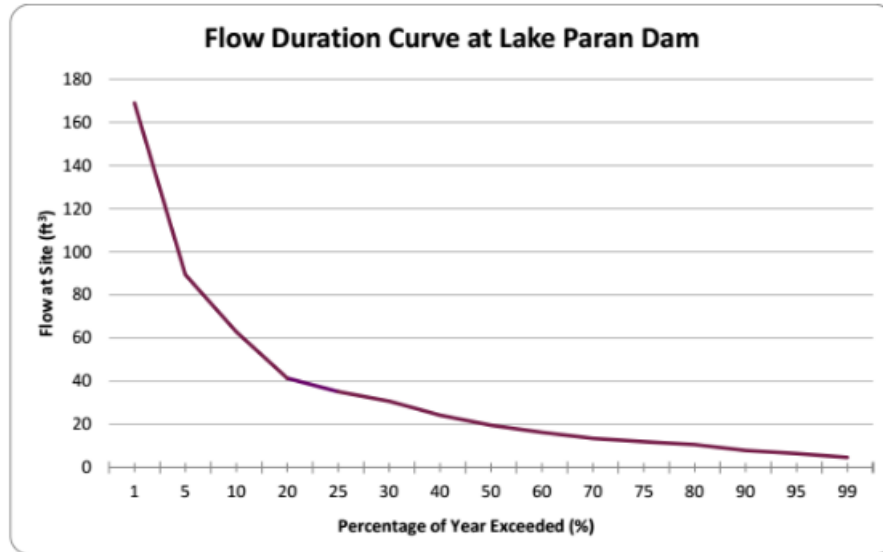

Flow Duration Statistics	
Percentage of Year Exceeded	Flow at Firehouse site (cubic feet per second)
1	168.93
5	89.32
10	62.85
20	41.35
15	52.10
25	35.15
30	30.74
40	24.26
50	19.57
60	16.26
70	13.51
75	11.99
80	10.61
90	7.87
95	6.48
99	4.69

SUMMARY OF SUPPLY QUOTE AND PROPOSED TERMS

Letter of Intent for Purchase of Equipment

The Firehouse Dam

October 27, 2016

Description This term sheet captures summary terms and conditions of an agreement for the sale and purchase of hydro electric generation equipment between Natel Energy, Inc. (“Natel”) and Scully Consulting Services (“Purchaser”), jointly the Parties.

Transaction Background This material is in response to an RFP by Scully Consulting Services dated September 29, 2016. Site characteristics were provided therein. Natel Energy has not directly assessed the site.

Project The Firehouse Dam, North Bennington Vermont, US

Rated Head 12.042 ft

Flow Data See flow duration curve in Appendix A.

Expected Installed Capacity

116 Energy Annual MWh	38 Max Power kW	35% Plant Factor	1 HydroEngine 1xPJ-7A-L	3.6 Design Head Meters	1.7 Max Flow CMS
-----------------------	-----------------	------------------	-------------------------	------------------------	------------------

Calculated a few seconds ago by jin@natelenergy.com

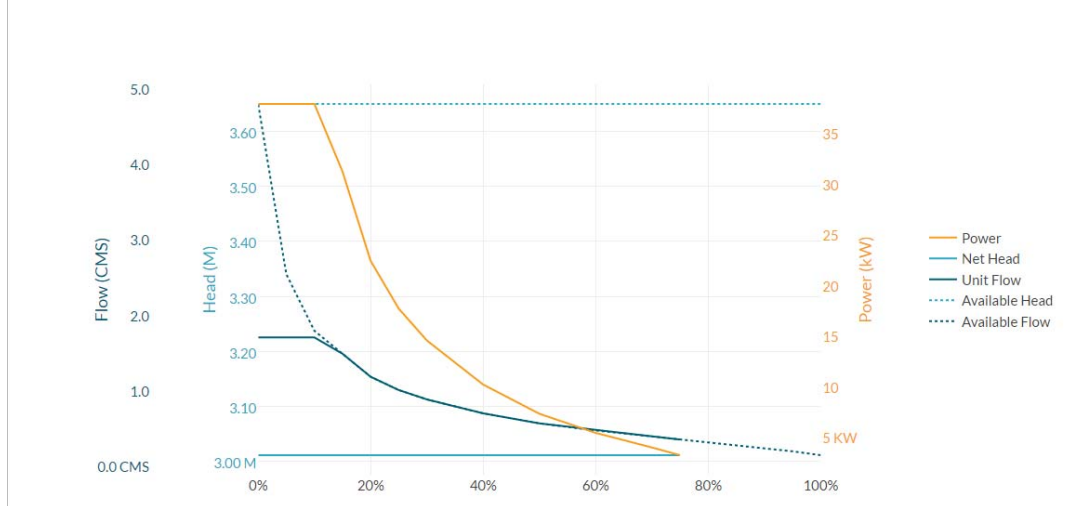

Natel Equipment Specified	<p>The following Natel SLH Systems will be supplied to the Purchaser.</p> <table border="1"> <thead> <tr> <th>SLH System</th> <th># Units</th> <th>Budgetary Cost Estimate</th> </tr> </thead> <tbody> <tr> <td>1xFJ-7A</td> <td>1</td> <td>\$180,000</td> </tr> </tbody> </table> <p>Unless otherwise noted herein, the following will be provided with each SLH System:</p> <ul style="list-style-type: none"> • SLH (housing + cassette + penstock adaptor) • Power Takeoff (generator + gearbox + alignment frame) • Controls (SCADA compliant) 	SLH System	# Units	Budgetary Cost Estimate	1xFJ-7A	1	\$180,000
SLH System	# Units	Budgetary Cost Estimate					
1xFJ-7A	1	\$180,000					
Estimated Delivery Date	<p>Natel's standard delivery window is 9 months from order for the first unit.</p> <p>Purchaser and Natel will keep each other apprised of the stage of the Project and update the delivery date as necessary. Until such time as a binding contract is signed, the Estimated Delivery Date is subject to change by either Party, without limitation.</p>						
Services Included	<p>The following are included with the purchase of the SLH system:</p> <ul style="list-style-type: none"> • Input on SLH integration into site design. • Interface with and consultation with customer EPC. <p>Technical Advisory Support at the Project Site during installation, Startup and Commissioning for 2 technicians full-time for 2 weeks.</p>						
Additional Services	<p>On site installation assistance beyond the commissioning activities will be provided at \$150 per hour.</p>						
Monitoring & Maintenance Service	<p>Purchaser will enter into a contract for either:</p> <ul style="list-style-type: none"> • Operations and Maintenance Service including all scheduled maintenance activities and parts and warranty-related unscheduled maintenance and parts for the period of 20 years, or • Condition Monitoring and Reporting Service for the period of 20 years, • at a rate to be determined based on timing of order and number of customer projects in the region 						
Warranty	<p>Natel provides a 2 year warranty on the SLH turbine</p>						
Expenses	<p>The parties will each bear their own legal and other expenses with respect to the transaction contemplated herein.</p>						

The preceding is an indicative summary of the terms and conditions for the proposed transaction between the Parties. This term sheet does not constitute an agreement, offer, nor a commitment to engage in the transaction described herein. In addition, the terms herein are not, nor meant to be, all-inclusive of the terms and conditions that the parties will require if they were to enter into a final and binding commitment. Any such final agreement shall be binding only upon execution of a fully negotiated and duly executed agreement. The Parties reserve the right, pending such final negotiation and execution, to modify the terms or abandon entirely the transaction proposed herein, without any liability to it. The Parties acknowledge that these materials are confidential and proprietary and mutually undertake not to disclose or provide these materials, or any information relating to the proposed transaction, without the consent of the Party providing the information, to any third parties, other than those authorized employees and advisors of recipient who need to know such information for the purposes of evaluating the proposed transaction.

Appendix A: RFP Data Request Items:
System efficiency curve:

99 Energy Annual MWh	18 Max Power kW	63% Plant Factor	1 HydroEngine 1xPJ-7A	3.6 Design Head Meters	0.8 Max Flow CMS
----------------------	-----------------	------------------	-----------------------	------------------------	------------------

Calculated 6 days ago by jin@natelenergy.com

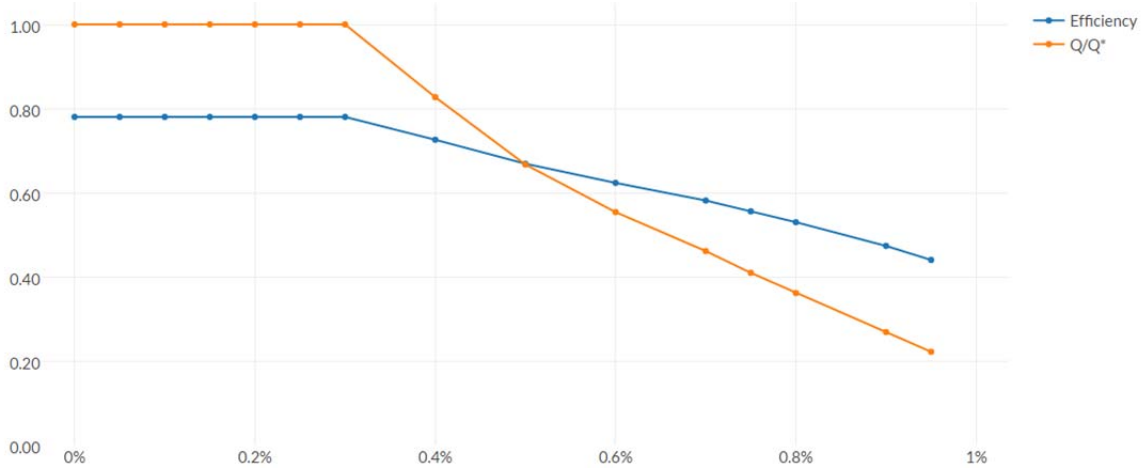

Exceedance %	Flow (CMS)	Power (kW)
100%	0.133	
95%	0.184	
90%	0.223	
80%	0.3	
75%	0.34	3.168
70%	0.383	3.926
60%	0.46	5.365
50%	0.554	7.249
40%	0.687	10.128
30%	0.871	14.47
25%	0.995	17.604
20%	1.171	22.313
15%	1.476	31.116
10%	1.78	37.789
5%	2.53	37.789
0%	4.784	37.789

Basic configuration drawings:

Our configuration suggestion that more closely matches the template you provided is presented below. It allows for a relatively inexpensive discharge downstream of the dam. There is no draft tube, but instead the hydroEngine sites on a cement box with discharge directly down. The path back to the downstream river can be either a simple channel or large diameter pipe and it is all at atmospheric pressure. A rough representation is presented here:



An alternate configuration may save considerably on civil and construction costs if it is allowable to locate the powerhouse downstream of the dam. This would eliminate almost all excavation, greatly reduce penstock and discharge channel costs and overall eliminate hydro footprint outside of the river. This is our “over tail race” configuration.

The main consideration may be how to get the water into the powerhouse intake by either notching the dam or adding short flashboards so the water selectively flowed over the dam at the location of the intake.

In the powerhouse there is a diversion to the hydroEngine or if the gate is opened all water discharges to the stream without going to the hydro.

A rough representation is presented here:



List clearly all equipment included in quotation.

Please see the standard term sheet above.

Services:

- List of all services included in quotation.
Please see the standard term sheet above.
- Information on manufacturer installation services required beyond scope of quotation.
Please see the standard term sheet above.

Assurances

- Provide any warranty and extended warranty information.
Please see the standard term sheet above.
- Detail any production guarantees.
Please see the standard term sheet above.
- All prices quoted must be good for 18 months.
Please see the standard term sheet above.

APPENDIX B: Flow Duration Curve at Firehouse Dam

Name: Firehouse Dam
 Location: North Bennington, Vermont, USA
 Basin: Basin 1 – Batten Kill, Walloomsac, Hoosic River Basin

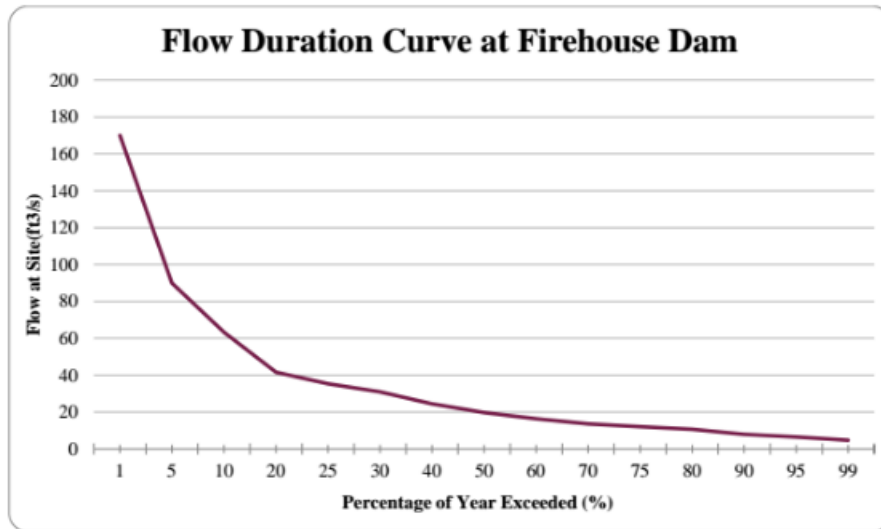

Flow Duration Statistics	
Percentage of Year Exceeded	Flow at Firehouse site (cubic feet per second)
1	170.04
5	89.90
10	63.26
20	41.62
15	52.44
25	35.38
30	30.94
40	24.42
50	19.70
60	16.37
70	13.60
75	12.07
80	10.68
90	7.91
95	6.52
99	4.72

Quote

P.I.T. Pipe Inc
keith@pitpipeinc.net
1-888-568-0984
Fax- 636-887-0560

DATE: OCTOBER 20, 2016

TO

William F. Scully
Recurrent Hydro
PO Box 338
North Bennington, Vermont 05257
(802) 379-2469

SALESPERSON	JOB	PAYMENT TERMS	DELIVERY
Keith Nuernberger	Stock	Net 30	As Needed

QTY	DESCRIPTION	UNIT PRICE	LINE TOTAL
250'	36"OD x .375" wall new spiral weld steel pipe made to length bevel x square ends includes cutting mitred angles	\$118.00	\$29,500.00
250'	Coating OD with Sherwin Williams macro epoxy 646	\$28.26	\$7,065.00
250'	Coating ID with Sherwin Williams macro epoxy 646	\$30.14	\$7,535.00
	Prices include delivery to the jobsite		